

# SIMPSON DOOR CO.

## HIGH IMPACT WOOD OUTSWING DOORS W/VO SIDELITE AND TRANSOMS

### INSTALLATION ANCHORAGE DETAILS

PROJECT NO. 421-0102									
									DATE
									DESCRIPTION
									REV

**SIMPSON DOOR COMPANY**  
400 SIMPSON AVE.  
MCCLEARY, WA 98557

TITLE: HIGH IMPACT WOOD OUTSWING DOORS W/VO SIDELITES/TRANSOMS  
GENERAL AND INSTALLATION NOTES

PREPARED BY: **RJA**      DATE: 6/18/21  
DRAWN BY: **RJA**      DRAWING NO: SIMP0027  
SCALE: **N.T.S.**      SHEET: 1 OF 20  
REV: ---

PTC Product Design Group, LLC  
Phone: 321.680.1788  
PO Box 520775  
Longwood, FL 32752-0775  
Email: info@pdc-corp.com  
FEB/CA. NO. 25835

**GENERAL NOTES:**

1. THIS PRODUCT HAS BEEN TESTED, EVALUATED AND DESIGNED TO THE CURRENT EDITION OF THE FLORIDA BUILDING CODE. TESTING WAS CONDUCTED IN ACCORDANCE WITH THE FOLLOWING.
  - 1.1. ASTM E283-04
  - 1.2. ASTM E547-00
  - 1.3. ASTM E331-00(09)
  - 1.4. ASTM E330-02(10)
  - 1.5. ASTM E1886-05/09
  - 1.6. ASTM E1996-06/09
2. THE PRODUCT DETAILS CONTAINED HEREIN ARE BASED UPON SIGNED AND SEALED TEST REPORT NO. NCTL-210-4190-16 AND ASSOCIATED LABORATORY DRAWINGS BY NATIONAL CERTIFIED TESTING LABORATORIES.
3. THIS PRODUCT EVALUATION DOCUMENT IS NOT FOR USE IN THE HIGH VELOCITY HURRICANE ZONE (HVHZ).
4. ADEQUACY OF THE EXISTING STRUCTURAL CONCRETE / MASONRY AND 2X FRAMING FRAMING SUBSTRATES AS A MAIN WIND FORCE RESISTING SYSTEM CAPABLE OF WITHSTANDING AND TRANSFERRING APPLIED PRODUCT LOADS TO THE FOUNDATION IS THE RESPONSIBILITY OF THE LICENSED PROFESSIONAL ENGINEER OR REGISTERED ARCHITECT ACTING AS THE DESIGN PROFESSIONAL OF RECORD FOR THE PROJECT OF INSTALLATION.
5. 1X AND 2X BUCKS (WHEN USED) SHALL BE DESIGNED AND ANCHORED TO PROPERLY TRANSFER ALL LOADS TO THE STRUCTURE. BUCK DESIGN AND INSTALLATION IS THE RESPONSIBILITY OF THE LICENSED PROFESSIONAL ENGINEER OR REGISTERED ARCHITECT ACTING AS THE DESIGN PROFESSIONAL OF RECORD FOR THE PROJECT OF INSTALLATION.
6. WHEN INSTALLED IN LOCATIONS WHERE WINDBORNE DEBRIS PROTECTION REQUIREMENTS EXIST, THIS PRODUCT DOES NOT REQUIRE OPENING PROTECTION.
7. SITE CONDITIONS NOT COVERED IN THIS PRODUCT EVALUATION DOCUMENT ARE SUBJECT TO ADDITIONAL ENGINEERING ANALYSIS BY A LICENSED PROFESSIONAL ENGINEER OR REGISTERED ARCHITECT AS REQUIRED BY THE AUTHORITY HAVING JURISDICTION.
8. MATERIAL AND HARDWARE
  - 8.1. FRAME MATERIAL: DOUGLAS FIR (OR EQUIVALENT SPECIFIC GRAVITY AND MODULUS OR ELASTICITY).
  - 8.2. LOCKSET: ENDURA TRILENNIUM 3500 OR 3020 MULTI-POINT LOCK OR HOPPE HLS9000 OR EQUIVALENT
  - 8.3. HINGES: SGS BB3000 OR EQUIVALENT
  - 8.4. SURFACE BOLT: IVES SB360-12 HD OR EQUIVALENT
9. GLASS MEETS THE REQUIREMENTS OF ASTM E1300-12AE1.
10. DESIGNATIONS "X" STANDS FOR OPERABLE AND "O" STANDS FOR FIXED.
11. THESE DRAWINGS CERTIFY THE DOOR INSTALLATION ONLY. WATER PROOFING OF THE INSTALLED DOOR INCLUDING PERIMETER SEALING AND SEALING THE SIDELITE TO THE DOOR FRAME IS NOT PART OF THIS INSTALLATION CERTIFICATION. THAT RESPONSIBILITY SHALL BE THAT OF THE MANUFACTURER AND/OR THE INSTALLER. ANY DETAILING SHOWN IS FOR ILLUSTRATIVE PURPOSES ONLY.
12. APPROVED DOOR ASSEMBLY CONFIGURATIONS.
  - 12.1. SHOWN IN ELEVATIONS ON SHEETS 3 THROUGH 8.
    - 12.1.1. OXXO, OO/OXXO, XX, O/XX, X, O/X
    - 12.1.2. SEE PERFORMANCE RATING TABLE ON THIS SHEET AND ELEVATIONS ON SHEETS 3 THROUGH 8 FOR MAXIMUM ASSEMBLY SIZES.
  - 12.2. NOT SHOWN. THE FOLLOWING ARE ENVELOPED BY THE ASSEMBLIES SHOWN.
    - 12.2.1. OXX, XXO, XO, OX, OO/XX, OO/XXO, O/XO, O/X
    - 12.2.2. TRANSOM WIDTH AND HEIGHT SHOWN ON SHEETS 3 THROUGH 8 CANNOT BE EXCEEDED ON ANY CONSTRUED ASSEMBLY IN 12.2.1 ABOVE.
    - 12.2.3. TRANSOM/PANEL CANNOT EXCEED 102.125" X 25.5". IF LONGER TRANSOM IS REQUIRED, IT MUST BE DIVIDED WITH AN ITEM NO. 7 VERTICAL MULLION AS SHOWN IN THE OO/OXXO ELEVATION.
13. APPROVED HORIZONTAL MULLION
  - 13.1. ITEM 7A MULLION SHALL BE USED ON ALL DOOR ASSEMBLIES THAT SPAN 107 INCHES OR LESS. THIS INCLUDES XO/X AND O/X SHOWN.
  - 13.2. ITEM 7B MULLION SHALL BE USED ON ALL DOOR ASSEMBLIES THAT SPAN GREATER THAN 107 INCHES. THIS INCLUDES OO/OXXO SHOWN.
  - 13.3. SEE SHEET 19 MULLION INSTALLATION NOTES FOR FURTHER DETAILS.

TABLE OF CONTENTS	
SHEET	SHEET DESCRIPTION
1	GENERAL NOTES, INSTALLATION NOTES, TABLE OF CONTENTS
2	ANCHOR SCHEDULE - EMBEDMENT AND EDGE DISTANCE
3	ELEVATION/ANCHOR LAYOUT - OXXO CONFIGURATION
4	ELEVATION/ANCHOR LAYOUT - XX CONFIGURATION
5	ELEVATION/ANCHOR LAYOUT - X CONFIGURATION
6	ELEVATION/ANCHOR LAYOUT - OO/OXXO CONFIGURATION
7	ELEVATION/ANCHOR LAYOUT - XX /O CONFIGURATION
8	ELEVATION/ANCHOR LAYOUT - O/X CONFIGURATION
9	VERTICAL SECTIONS - ALUMINUM SILL - OXXO, XX AND X CONFIGURATIONS
10	VERTICAL SECTIONS - WOOD SILL - OXXO, XX AND X CONFIGURATIONS
11	VERTICAL SECTIONS - TRANSOM
12	HORIZONTAL SECTIONS - OXXO CONFIGURATION
13	HORIZONTAL SECTIONS - XX & X CONFIGURATIONS
14	HORIZONTAL SECTIONS - TRANSOM
15	BILL OF MATERIALS / GLAZING DETAILS
16	END CONNECTION & SURFACE BOLT DETAILS
17	HINGE AND LOCKSET DETAILS
18	MULLION DETAILS
19	MULLION DETAILS
20	APPROVED PANEL CONFIGURATIONS

PERFORMANCE RATING				
MAXIMUM DOOR SIZE	GLAZING DETAIL (SEE SHEET 15)	DESIGN PRESSURE (PSF)	LIMITED WATER RESISTANCE RATING	IMPACT RATING (SEE GENERAL NOTE 6)
141-3/8" x 110-3/4" OXXO	A, B, C	+/- 50	No Leakage after 4 cycle(s) of 5 minutes at 0.00 psf per ASTM E547-00 and ASTM E331-00 (09) (SEE NOTE 1 BELOW)	WIND ZONE 4, MISSILE LEVEL D
141-3/8" x 138-1/4" OO/OXXO	A, B, C	+/- 50		
86-3/8" x 110-3/4" XX	A, B, C	+/- 50		
86-3/8" x 138-1/4" O/XX	A, B, C	+/- 50		
44" x 110-3/4" X	A, B, C	+/- 50		
44" x 138-1/4" O/X	A, B, C	+/- 50		

Note 1: OVERHANG IN ACCORDANCE WITH REQUIREMENT BELOW CAN BE USED PER CHAPTER 17 OF FBC.  
 1. Door assemblies installed where the overhang (OH) ratio is equal to or more than 1 do not have to meet the water infiltration requirements. The overhang ratio shall be calculated by the following equation.  
 2. OH ratio = OH Length/OH Height, Where:  
 2.1. OH length = The horizontal measure of how far an overhang over a door projects out from door surface.  
 2.2. OH height = The vertical measure of the distance from the door sill to the bottom of the overhang over a door.

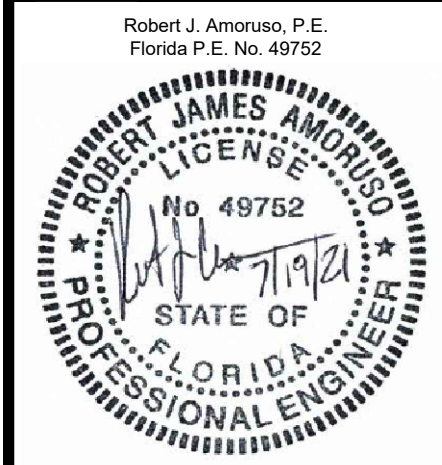

## THROUGH FRAME INSTALLATION ANCHOR SCHEDULE

INSTALLATION TYPE	FASTENER HEAD TYPE	FASTENER SIZE	SUBSTRATE	MANUFACTURER AND/OR SPECIFICATION	MIN. EMBEDMENT	MIN. EDGE DISTANCE (IN)	MIN. SPACING (IN)	ANCHOR CAPACITIES BASED ON
THROUGH FRAME ANCHOR	FLAT HEAD	3/16"	CONCRETE	ITW TAPCONS (1)	1-1/2	1-1/8	3	MIN. 2500 PSI CONCRETE
			MASONRY (BLOCK/CMU)	ITW TAPCONS (1)	1	2	3	STRENGTH CONFORMANCE TO ASTM C-90, MEDIUM WEIGHT
	FLAT HEAD	No. 10	WOOD	ANSI B18.6.1 (WOOD SCREW) (2) GRADE 2 EQUIVALENT	1-3/8	3/4	2 1/2	WOOD WITH A MINIMUM SPECIFIC GRAVITY OF 0.42.

**NOTES:**

- 1) WHEN ITW TAPCONS ARE USED FOR CONCRETE/MASONRY INSTALLATION, THEY SHALL BE THE ADVANCED THREADFORM TECHNOLOGY TYPE.
- 2) FOR WOOD SCREW INSTALLATION INTO WOOD SUBSTRATE; IF SPLITTING IS A CONCERN, DRILL 0.112" PILOT HOLE (DRILL SIZE 34).

## EDGE DISTANCE AND EMBEDMENT

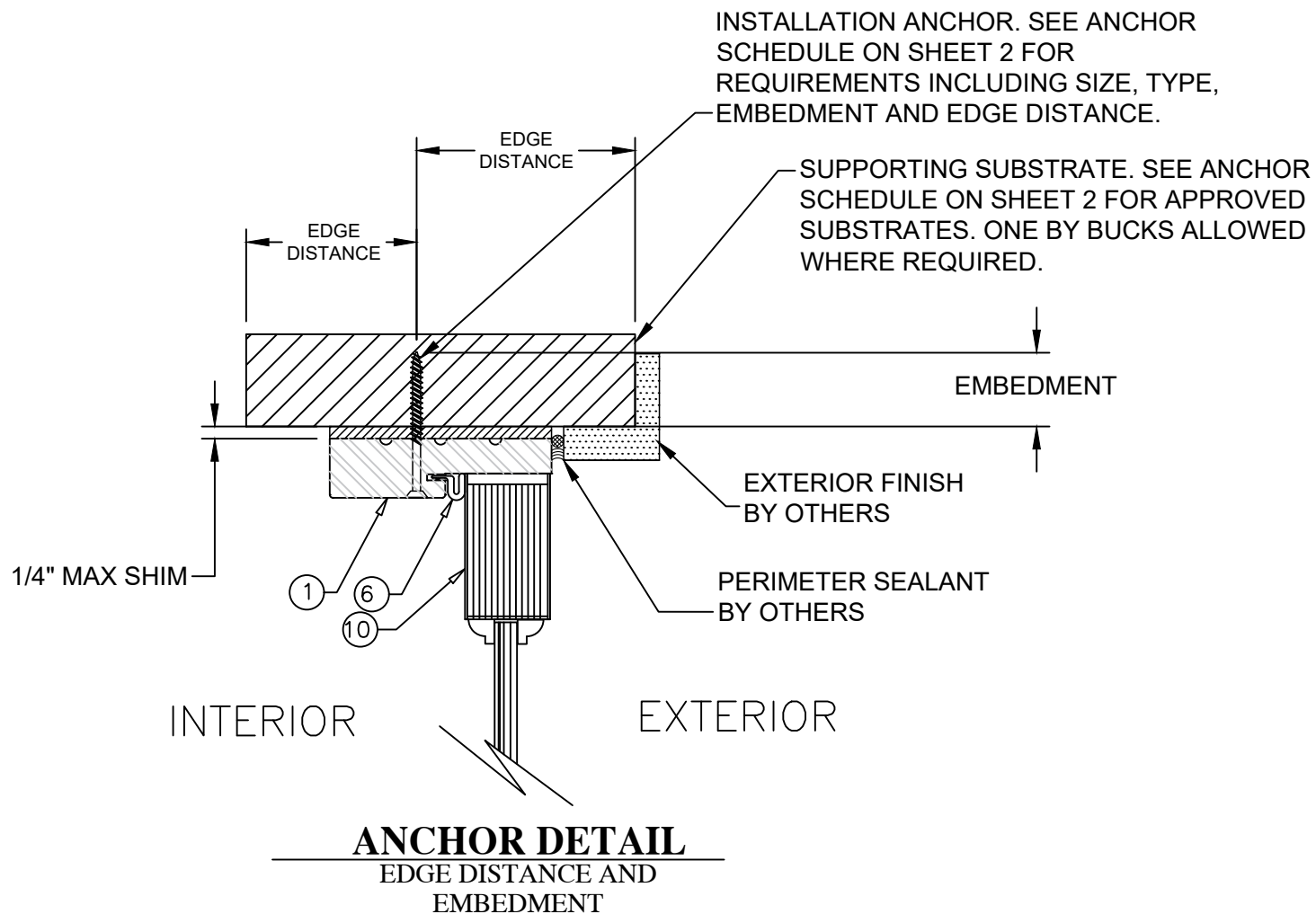

**INSTALLATION NOTES:**

1. PRODUCT ANCHORS SHALL BE AS DESIGNATED AND LOCATED AS SHOWN IN THIS PRODUCT EVALUATION DOCUMENT. ANCHOR EMBEDMENT AND EDGE DISTANCE EXCLUDE WALL FINISHES, INCLUDING BUT NOT LIMITED TO STUCCO, FOAM, BRICK VENEER AND SIDING.
2. SEE INSTALLATION ANCHOR SCHEDULE ON SHEET 2 FOR TYPE AND GRADE OF ANCHOR, AND/OR MANUFACTURER'S ANCHOR SPECIFICATIONS, INCLUDING MINIMUM NOMINAL SIZE, MINIMUM EMBEDMENT INTO SUBSTRATE AND MINIMUM EDGE DISTANCES.
3. EDGE DISTANCES SHALL BE MEASURED FROM CENTERLINE OF ANCHOR TO EDGE OF STRUCTURAL SUBSTRATE EITHER TO THE INTERIOR OR EXTERIOR OF THE FENESTRATION PRODUCT.
4. MINIMUM EMBEDMENT SHALL BE BASED ON PENETRATION INTO MAIN WIND FORCE RESISTING SYSTEM SUBSTRATE.
5. SEE SHEETS 9 THROUGH 14 FOR SPECIFIC ANCHOR INSTALLATION DETAILS.
6. ONE (1) INSTALLATION ANCHOR IS REQUIRED AT EACH ANCHOR LOCATION SHOWN.
7. ANCHOR QUANTITIES AND SPACING / EMBEDMENT AND EDGE DISTANCE
  - 7.1. THE NUMBER OF INSTALLATION ANCHORS IS BASED ON THE MAXIMUM END DISTANCE (ED) AND THE MAXIMUM ON CENTER (O.C.) SPACING PLACEMENT OF ANCHORS IN ACCORDANCE WITH THE ANCHOR ELEVATIONS ON SHEETS 3, 4, 5, 6, 7 AND 8.
  - 7.2. END DISTANCES AND O.C. SPACING LESS THAN THAT SHOWN IN THE ELEVATIONS ON SHEETS 3, 4, 5, 6, 7 AND 8 ARE ACCEPTABLE.
  - 7.3. FOR DOOR SIZES SMALLER THAN THOSE SHOWN, ANCHOR QUANTITIES CAN BE REDUCED WHILE MAINTAINING EDGE DISTANCE AND O.C. SPACING REQUIREMENTS.
  - 7.4. ANCHOR QUANTITIES AND SPACINGS SHOWN ARE BASED ON THE LOWER OF ANCHOR SPACING USED IN TESTING OR REQUIRED BY LOADING AT DESIGN PRESSURE.
  - 7.5. SEE EMBEDMENT AND EDGE DISTANCE DESCRIPTION ON SHEET 2.
8. MAXIMUM ALLOWABLE SHIM THICKNESS IS 1/4 INCH. SHIM WHERE SPACE OF 1/16 INCH OR GREATER OCCURS. SHIM(S) SHALL BE CONSTRUCTED OF WOOD COMPOSITE, HIGH DENSITY PLASTIC OR SIMILAR LOAD BEARING MATERIAL.
9. FOR CONCRETE BLOCK APPLICATIONS DO NOT INSTALL INSTALLATION ANCHORS INTO MORTAR JOINTS.
10. INSTALLATION ANCHORS SHALL BE INSTALLED IN ACCORDANCE WITH ANCHOR MANUFACTURER'S INSTALLATION INSTRUCTIONS AND ANCHORS SHALL NOT BE USED IN SUBSTRATES WITH STRENGTHS LESS THAN THE MINIMUM STRENGTH SPECIFIED IN THE INSTALLATION ANCHOR SCHEDULE ON SHEET 2.
11. ALL FASTENERS (ANCHORS) SHALL BE MADE OF CORROSION RESISTANT MATERIAL OR PROTECTED WITH A CORROSION RESISTANT COATING.

PROJECT NO. 421-0102

SIMPSON DOOR COMPANY  
400 SIMPSON AVE.  
MCCLEARY, WA 98557

TITLE: HIGH IMPACT WOOD OUTSWING DOORS W/WO SIDELITES/TRANSOMS  
ANCHOR SCHEDULE

DRAWN BY: RJA  
DATE: 6/18/21

SCALE: N.T.S.  
DRAWING NO: SIMP0027

REV: ---  
SHEET: 2 OF 20

Robert J. Amoroso, P.E.  
Florida P.E. No. 49752

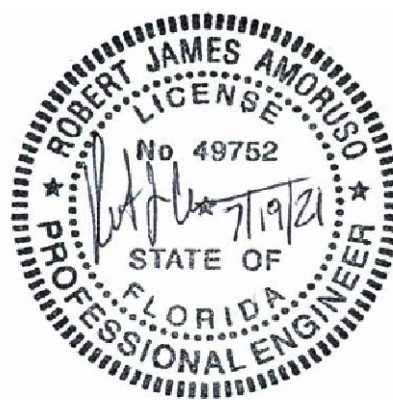

# SERIES "HIGH IMPACT" OXXO WOOD OUTSWING DOOR WITH SIDELITES

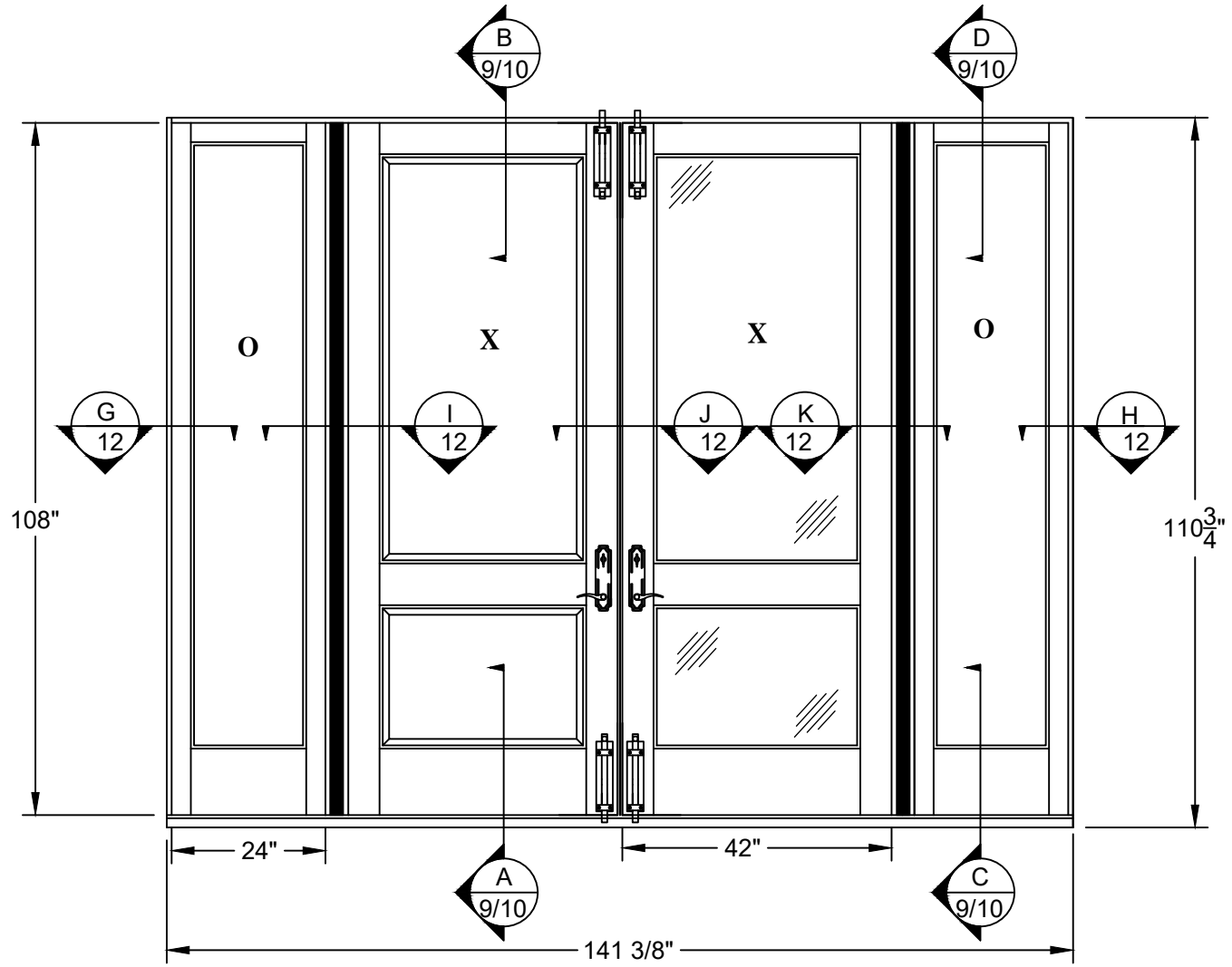

**ELEVATION**  
INTERIOR VIEW

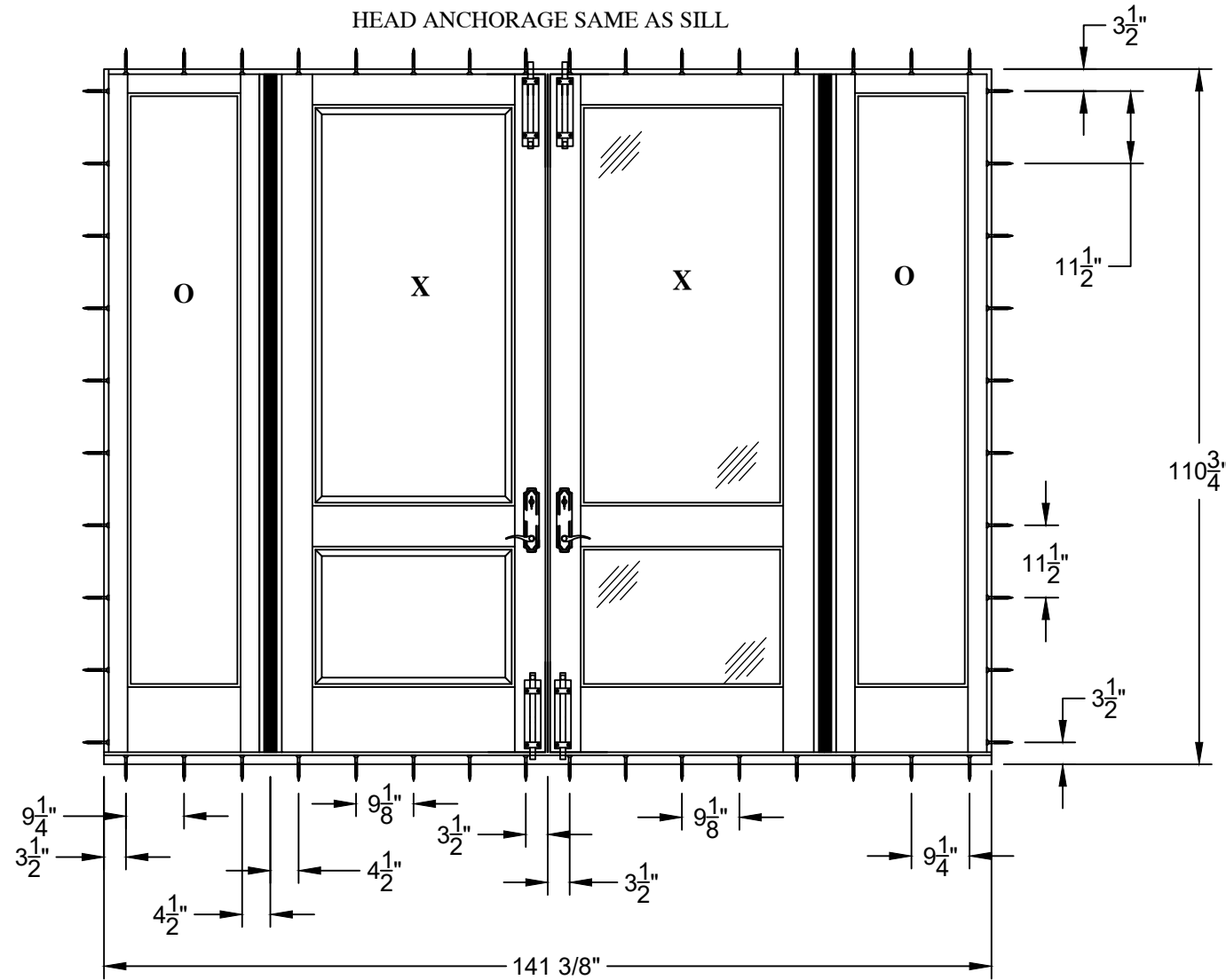

**ELEVATION - ANCHOR LAYOUT**  
INTERIOR VIEW

**COMPONENT SIZES:**

1. MAXIMUM FRAME SIZE - 141 3/8" X 110 3/4"
2. MAXIMUM PANEL SIZE - 42" X 108"
3. SIDELITE PANEL SIZE - 24" X 108"
4. DAYLIGHT OPENING
  - 4.1. DOOR PANELS MAXIMUM - 31 1/4" X 91 3/4"
  - 4.2. SIDELITE MAXIMUM - 17" X 93 5/8"

PROJECT NO. 421-0102	REV	DATE	BY
SIMPSON DOOR COMPANY 400 SIMPSON AVE. MCCLEARY, WA 98557	DRAWING NO. SIMP0027	DATE:	6/18/21
		DRAWN BY:	RJA
TITLE: HIGH IMPACT WOOD OUTSWING DOORS WWO SIDELITES/TRANSOMS ELEVATION/ANCHOR LAYOUT - OXXO CONFIGURATION		SCALE:	N.T.S.
PREPARED BY:		REV:	---
		REV:	3 OF 20
PTC Product Design Group, LLC PO Box 320775 Lenexa, KS 66247-2075 FBPE GA. NO. 25595		Phone: 321.690.1788 Fax: 321.690.1789 Email: info@ptc-corp.com	

Robert J. Amoruso, P.E.  
Florida P.E. No. 49752

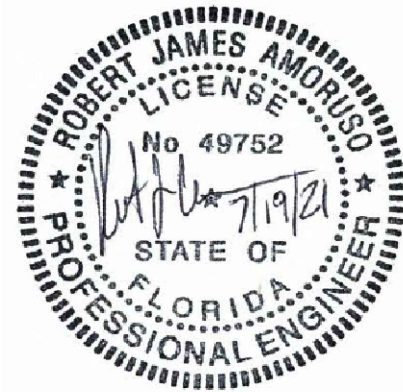

# SERIES "HIGH IMPACT" OXXO WOOD OUTSWING DOOR WITH SIDELITES AND TRANSOMS

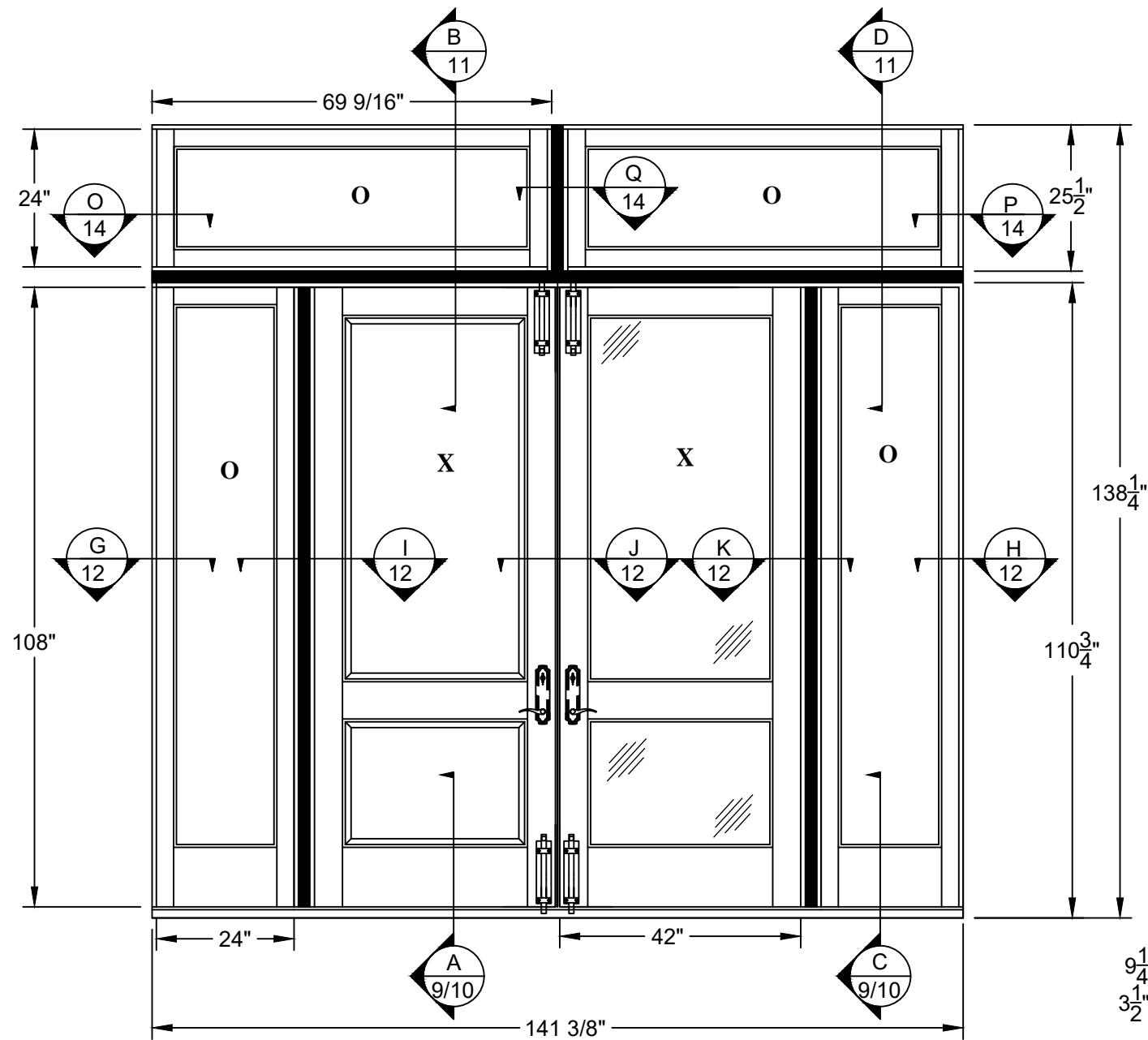

**ELEVATION**  
INTERIOR VIEW

**COMPONENT SIZES:**

1. FRAME AND PANEL
  - 1.1. MAXIMUM FRAME SIZE - 141 3/8" X 138 1/4"
  - 1.2. MAXIMUM PANEL SIZE - 42" X 108"
  - 1.3. SIDELITE PANEL SIZE - 24" X 108"
  - 1.4. TRANSOM PANEL SIZE - 68 1/16" X 24"
2. GLAZING DAYLIGHT OPENING
  - 2.1. DOOR PANELS MAXIMUM - 31 1/4" X 91 3/4"
  - 2.2. SIDELITE MAXIMUM - 17" X 93 5/8"
  - 2.3. TRANSOM MAXIMUM - 17" X 61 1/32"

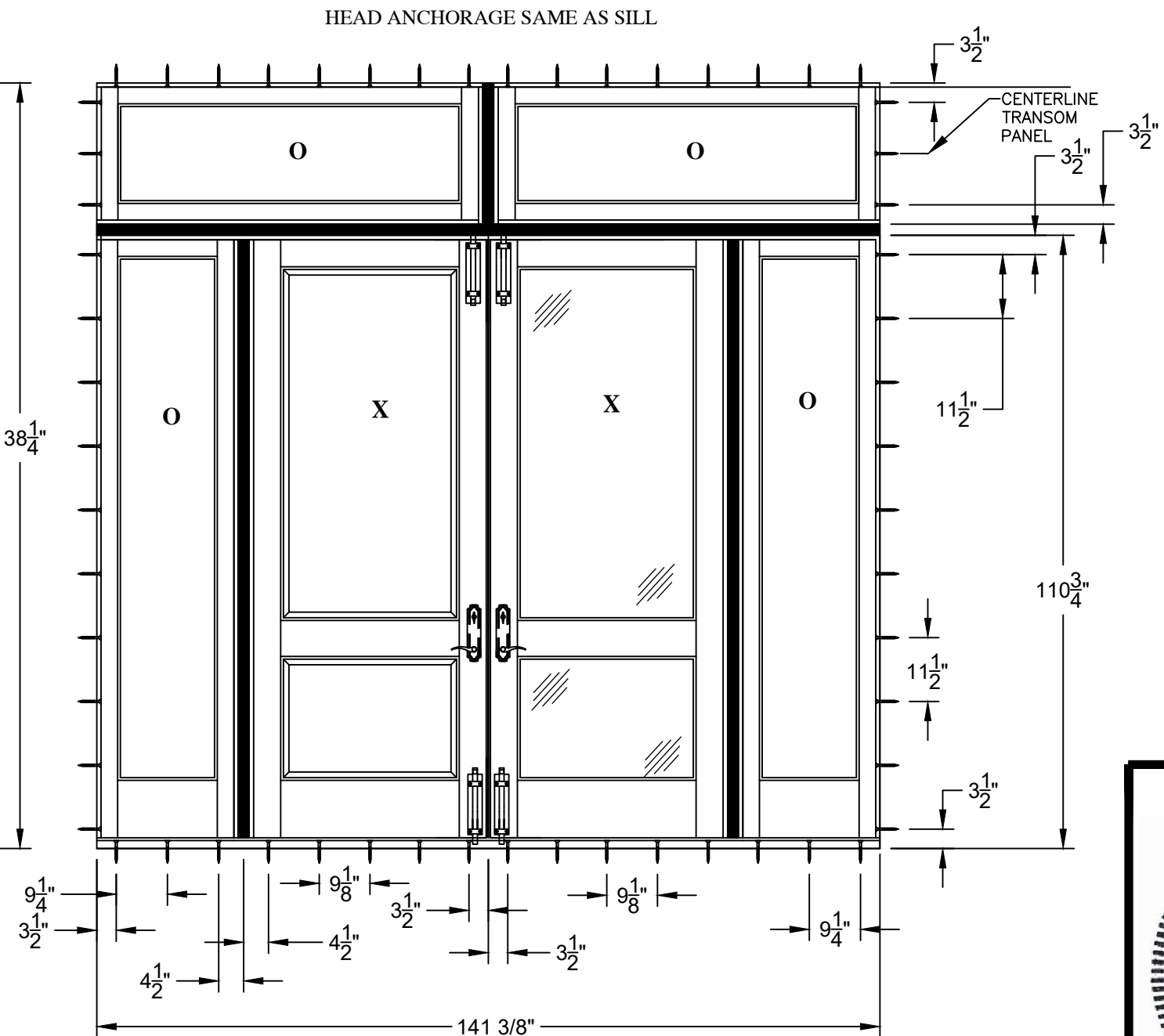

**ELEVATION - ANCHOR LAYOUT**  
INTERIOR VIEW

PROJECT NO. 421-0102	

<b>SIMPSON DOOR COMPANY</b> 400 SIMPSON AVE. MCCLEARY, WA 98557			
TITLE: HIGH IMPACT WOOD OUTSWING DOORS W/WO SIDELITES/TRANSOMS ELEVATION/ANCHOR LAYOUT - OO/OXXO CONFIGURATION			
DATE:	6/18/21	DRAWING NO.:	SIMP0027
DRAWN BY:	RJA	SCALE:	N.T.S.
PREPARED BY:	---	REV.:	---
PDC Product Design Group, LLC PO Box 320775 Las Vegas, NV 89175 Phone: 321.690.1788 Fax: 321.690.1789 Email: info@pdc-corp.com FBPE CA NO. 25595			

Robert J. Amoruso, P.E.  
Florida P.E. No. 49752





# SERIES "HIGH IMPACT" XX WOOD OUTSWING DOOR

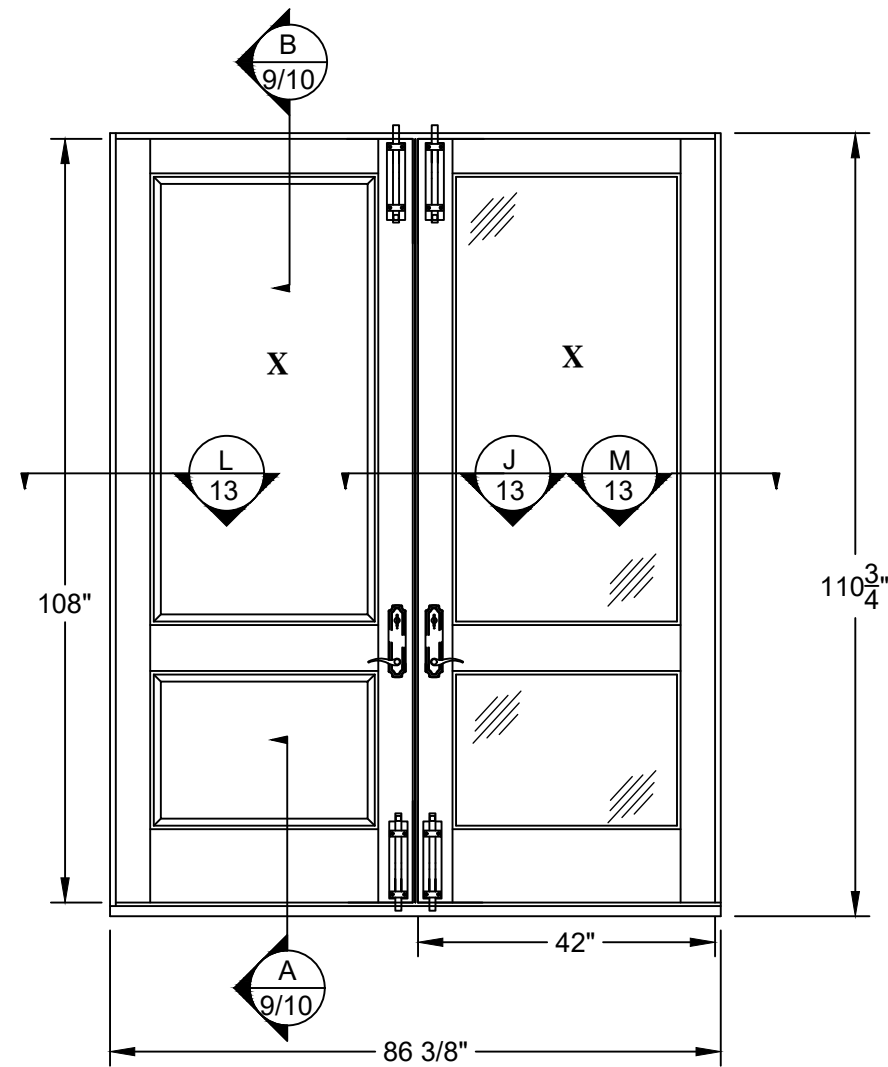

**ELEVATION**  
INTERIOR VIEW

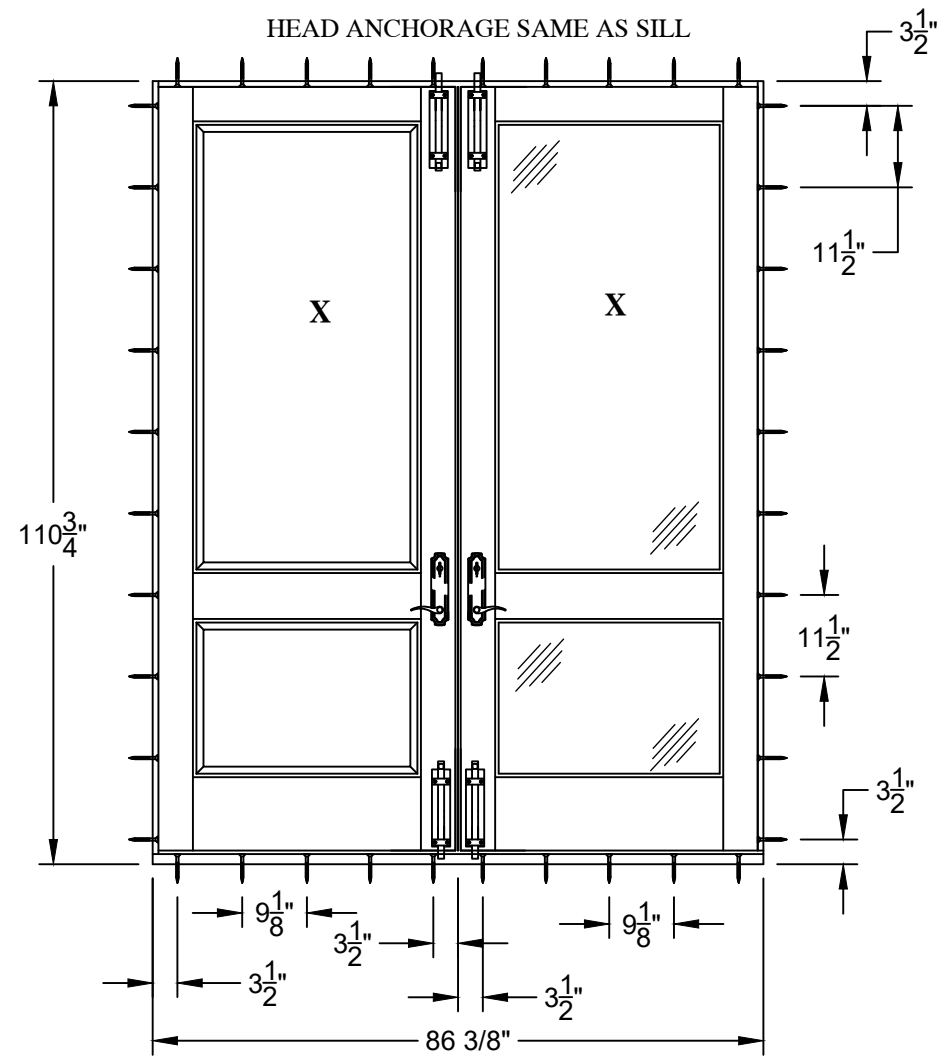

**ELEVATION - ANCHOR LAYOUT**  
INTERIOR VIEW

**COMPONENT SIZES:**

1. MAXIMUM FRAME SIZE -  $86 \frac{3}{8}$ " X  $110 \frac{3}{4}$ "
2. MAXIMUM PANEL SIZE - 42" X 108"
3. DOOR PANEL DAYLIGHT OPENING MAXIMUM -  $31 \frac{1}{4}$ " X  $91 \frac{3}{4}$ "

PROJECT NO. 421-0102

SIMPSON DOOR COMPANY  
400 SIMPSON AVE.  
MCCLEARY, WA 98557

TITLE: HIGH IMPACT WOOD OUTSWING DOORS W/WO SIDELITES/TRANSOMS  
ELEVATION/ANCHOR LAYOUT - XX CONFIGURATION

PREPARED BY:	DATE:	DRAWING NO.:	SHEET:
RJA	6/18/21	SIMP0027	5 OF 20
SCALE: N.T.S.	REV:		



Robert J. Amoruso, P.E.  
Florida P.E. No. 49752



# SERIES "HIGH IMPACT" XX WOOD OUTSWING DOOR WITH TRANSOM

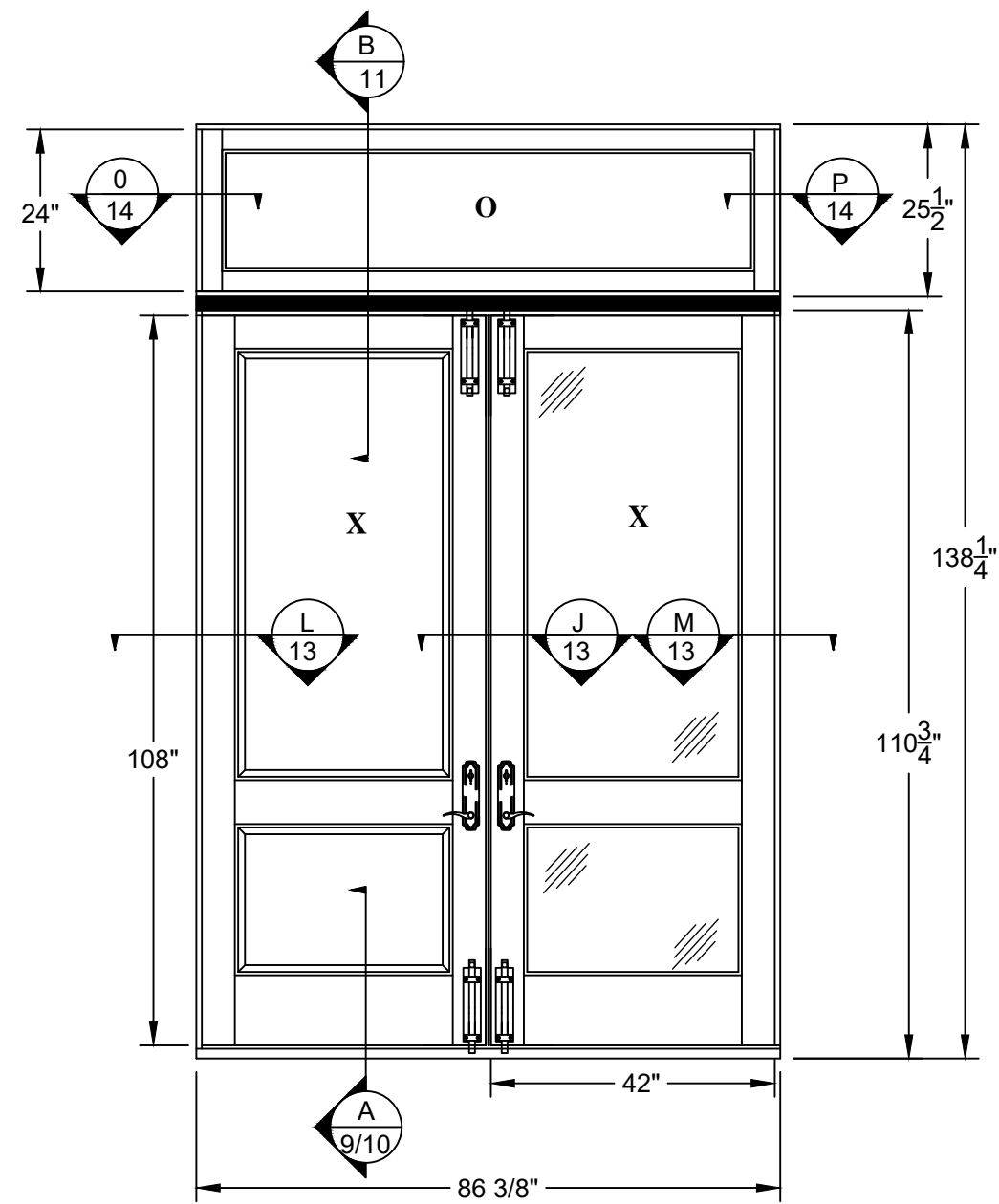

**ELEVATION**  
INTERIOR VIEW

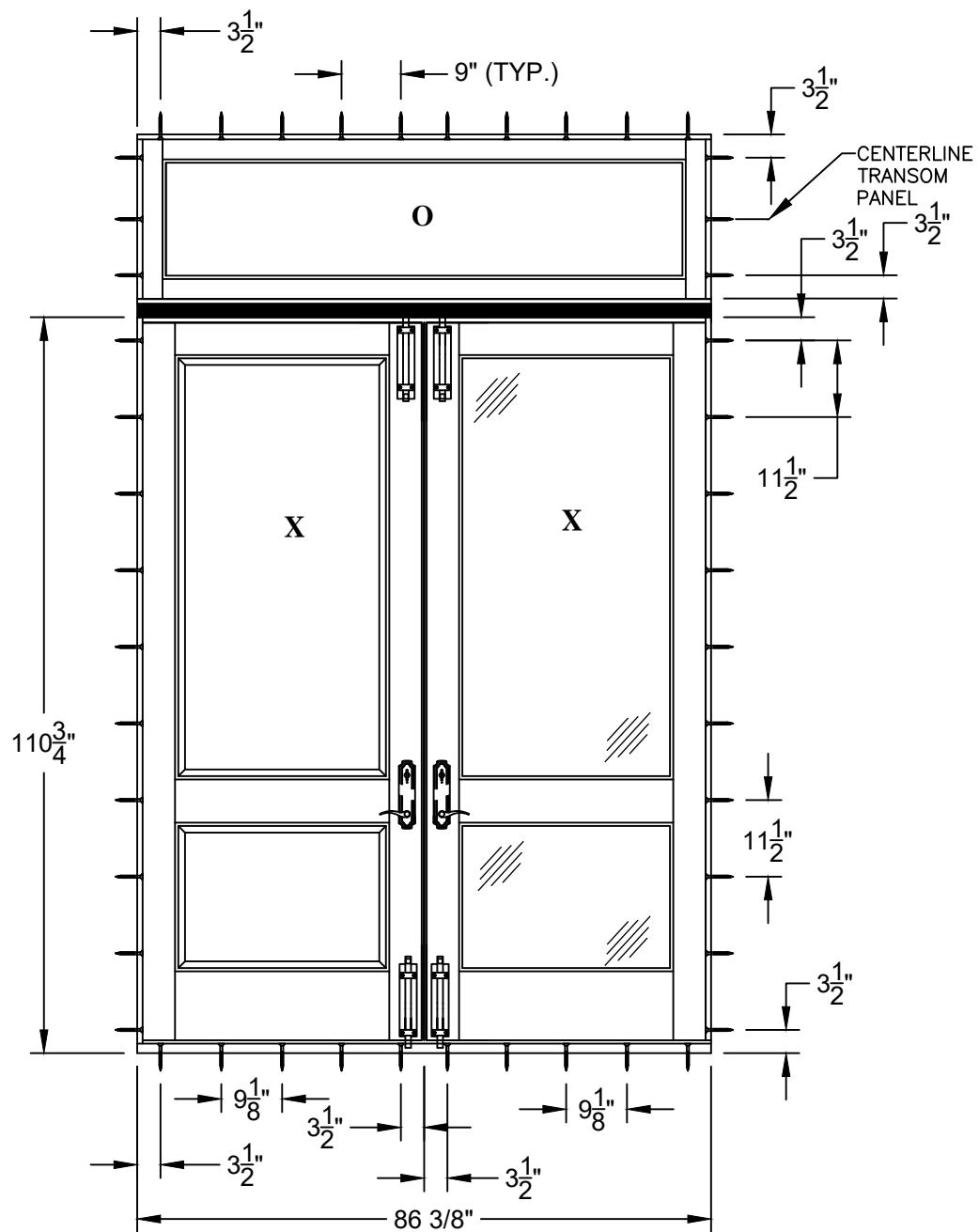

**ELEVATION - ANCHOR LAYOUT**  
INTERIOR VIEW

**COMPONENT SIZES:**

1. FRAME AND PANEL
  - 1.1. MAXIMUM FRAME SIZE -  $86\frac{3}{8}$ " X  $138\frac{1}{4}$ "
  - 1.2. MAXIMUM PANEL SIZE - 42" X 108"
  - 1.3. TRANSOM PANEL SIZE -  $86\frac{3}{8}$ " X 24"
2. GLAZING DAYLIGHT OPENING
  - 2.1. DOOR PANEL MAXIMUM -  $31\frac{1}{4}$ " X  $91\frac{3}{4}$ "
  - 2.3. TRANSOM MAXIMUM - 17" X  $77\frac{3}{4}$ "

PROJECT NO. 421-0102	REV	DESCRIPTION	DATE	BY

**SIMPSON DOOR COMPANY**  
400 SIMPSON AVE.  
MCCLEARY, WA 98557

TITLE: HIGH IMPACT WOOD OUTSWING DOORS W/WO SIDELITES/TRANSOMS  
ELEVATION/ANCHOR LAYOUT - O/XX CONFIGURATION

PREPARED BY: RJA  
SCALE: N.T.S.  
DATE: 6/18/21  
DRAWING NO: SIMP0027  
SHEET: 6 OF 20

PTC Product Design Group, LLC  
PO Box 320775  
Lenexa, KS 66157-0775  
Phone: 321.690.1788  
Fax: 321.690.1789  
Email: info@ptc-corp.com  
FBPE CA. NO. 25595

Robert J. Amoruso, P.E.  
Florida P.E. No. 49752

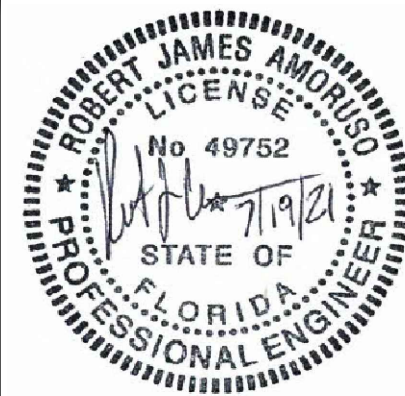

# SERIES "HIGH IMPACT" X WOOD OUTSWING DOOR

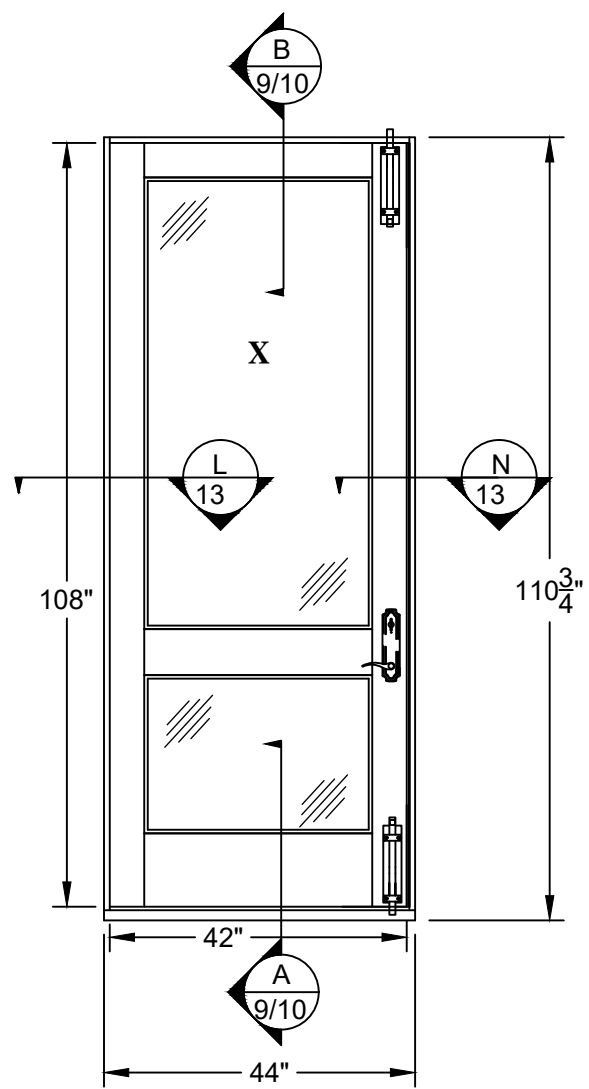

**ELEVATION**  
INTERIOR VIEW

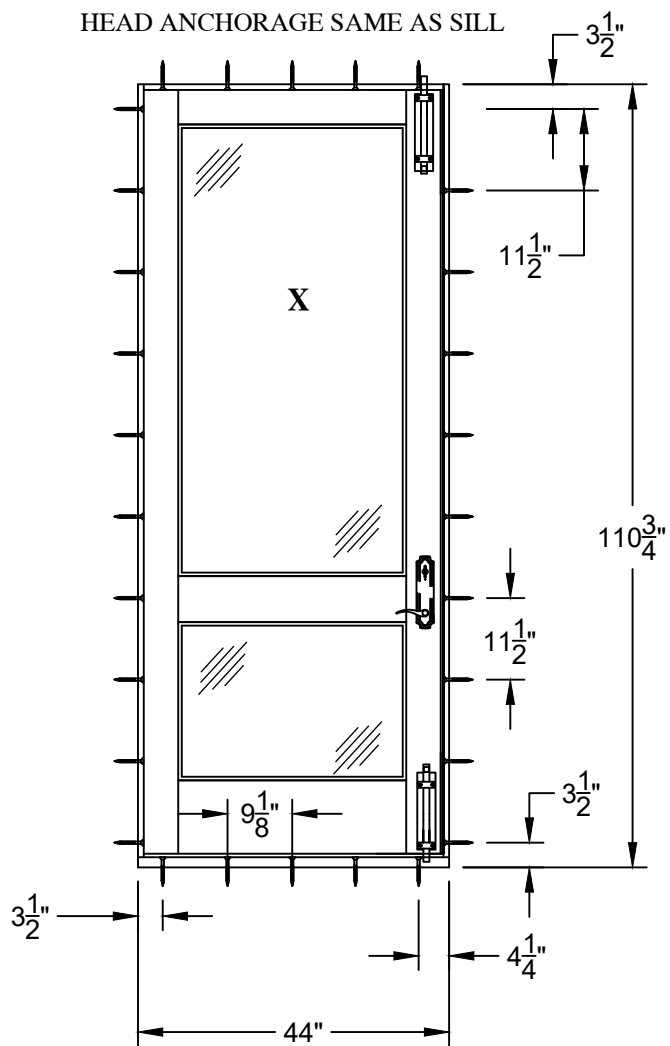

**ELEVATION - ANCHOR LAYOUT**  
INTERIOR VIEW

- COMPONENT SIZES:
1. MAXIMUM FRAME SIZE - 44 <sup>3</sup>/<sub>8</sub>" X 110 <sup>3</sup>/<sub>4</sub>"
  2. MAXIMUM PANEL SIZE - 42" X 108"
  3. DOOR PANEL DAYLIGHT OPENING MAXIMUM - 31 <sup>1</sup>/<sub>4</sub>" X 91 <sup>3</sup>/<sub>4</sub>"

PROJECT NO. 421-0102			
REV	DESCRIPTION	DATE	BY

**SIMPSON DOOR COMPANY**  
400 SIMPSON AVE.  
MCCLEARY, WA 98557

TITLE: HIGH IMPACT WOOD OUTSWING DOORS W/WO SIDELITES/TRANSOMS  
ELEVATION/ANCHOR LAYOUT - X CONFIGURATION

PREPARED BY: RJA  
DATE: 6/18/21  
SCALE: N.T.S.  
DRAWING NO: SIMP0027  
SHEET: 7 OF 20

PTC Product Design Group, LLC  
PO Box 320775  
Lenoir, NC 27539  
Phone: 321.690.1788  
Fax: 321.690.1789  
Email: info@ptc-corp.com  
FBPE GA. NO. 25585



# SERIES "HIGH IMPACT" X WOOD OUTSWING DOOR AND TRANSOM

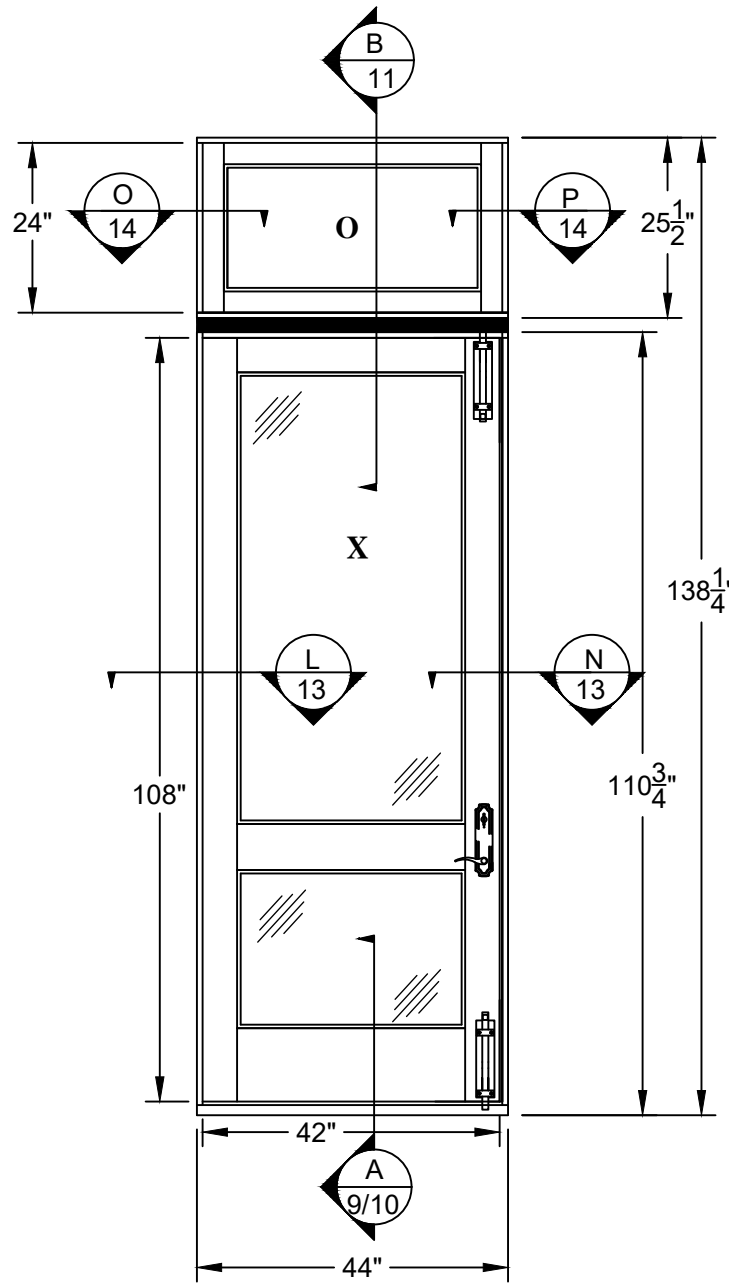

**ELEVATION**  
INTERIOR VIEW

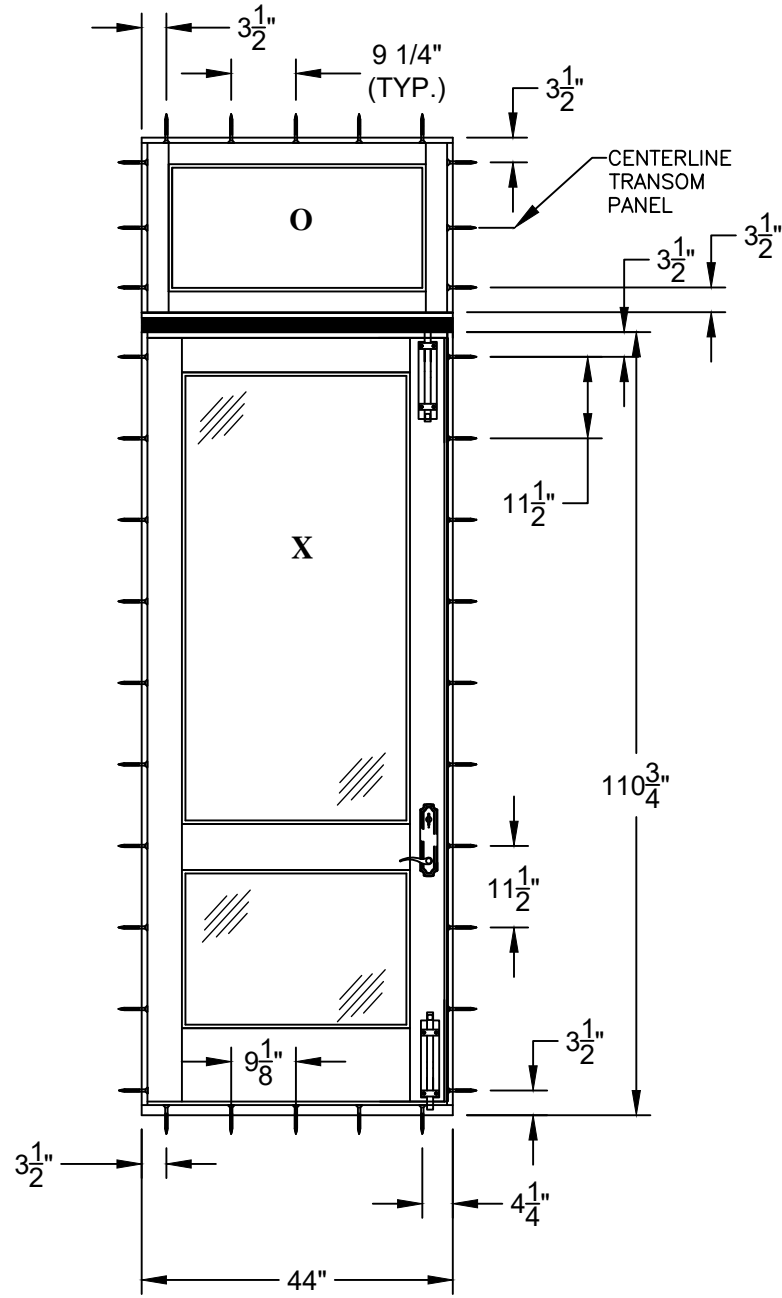

**ELEVATION - ANCHOR LAYOUT**  
INTERIOR VIEW

- COMPONENT SIZES:
1. FRAME AND PANEL
    - 1.1. MAXIMUM FRAME SIZE - 44" X 138 1/4"
    - 1.2. MAXIMUM PANEL SIZE - 42" X 108"
    - 1.3. TRANSOM PANEL SIZE - 44" X 25 1/2"
  2. GLAZING DAYLIGHT OPENING
    - 2.1. DOOR PANELS MAXIMUM - 31 1/4" X 91 3/4"
    - 2.2. TRANSOM MAXIMUM - 17" X 35 3/8"

PROJECT NO. 421-0102

REV	DESCRIPTION	DATE	BY

**SIMPSON DOOR COMPANY**  
400 SIMPSON AVE.  
MCCLEARY, WA 98557

TITLE: HIGH IMPACT WOOD OUTSWING DOORS W/WO SIDELITES/TRANSOMS  
ELEVATION/ANCHOR LAYOUT - OIX CONFIGURATION

PREPARED BY: RJA  
SCALE: N.T.S.  
REV: ---

DATE: 6/18/21  
DRAWING NO: SIMP0027  
SHEET: 8 OF 20

PTC Product Design Group, LLC  
PO Box 320775  
Lynchburg, VA 24507-0775  
Phone: 321.690.1788  
Fax: 321.690.1789  
Email: info@pdc-corp.com  
FBPE C.A. NO. 25595

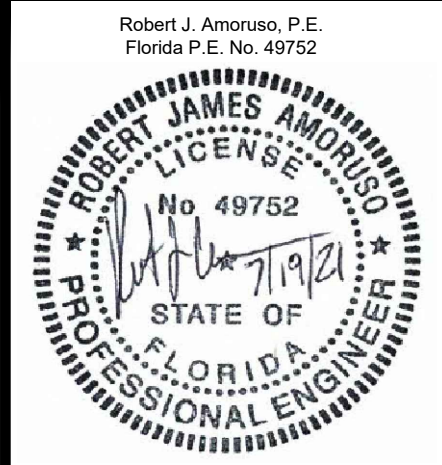



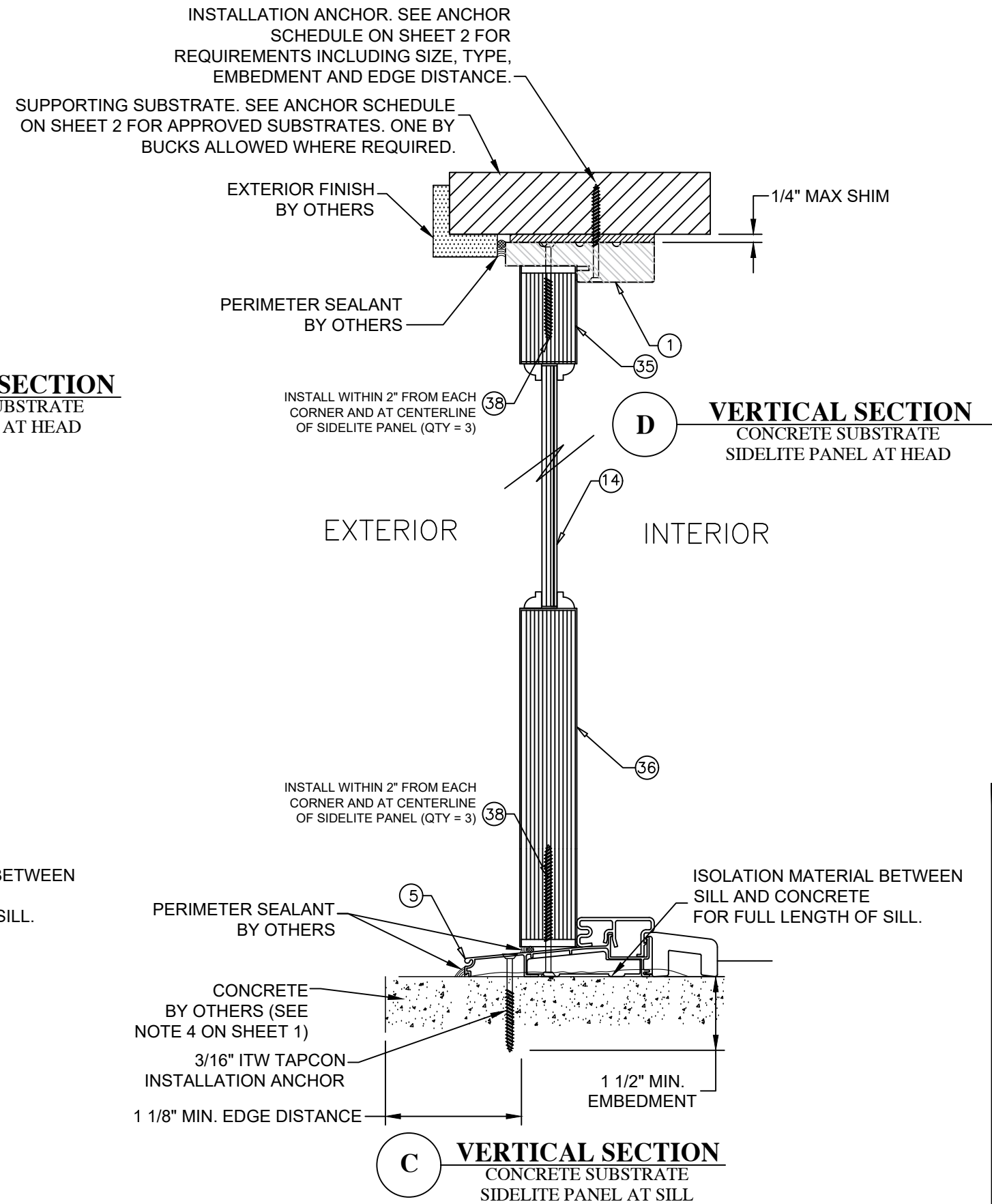
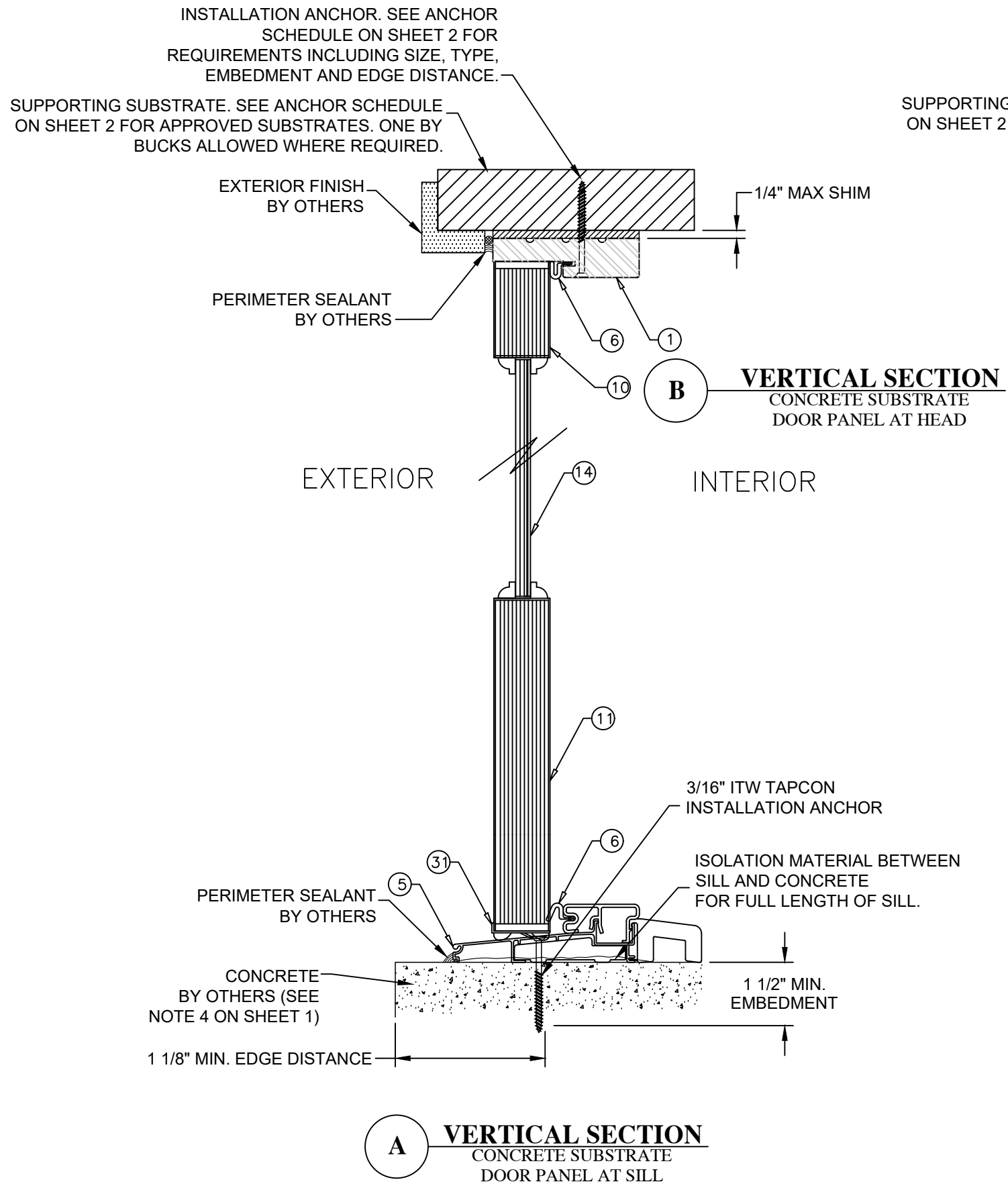

PROJECT NO. 421-0102

REV	DESCRIPTION	DATE	BY

SIMPSON DOOR COMPANY  
400 SIMPSON AVE.  
MCCLEARY, WA 98557

TITLE: HIGH IMPACT WOOD OUTSWINGING DOORS W/VO SIDELITES/TRANSOMS  
VERTICAL SECTIONS - ALUMINUM SILL

PREPARED BY: RJA  
SCALE: N.T.S.  
DATE: 6/18/21  
DRAWING NO.: SIMP0027  
SHEET: 9 OF 20

Phone: 321.690.1788  
Fax: 321.690.1789  
Email: info@gdc-corp.com

Robert J. Amoruso, P.E.  
Florida P.E. No. 49752

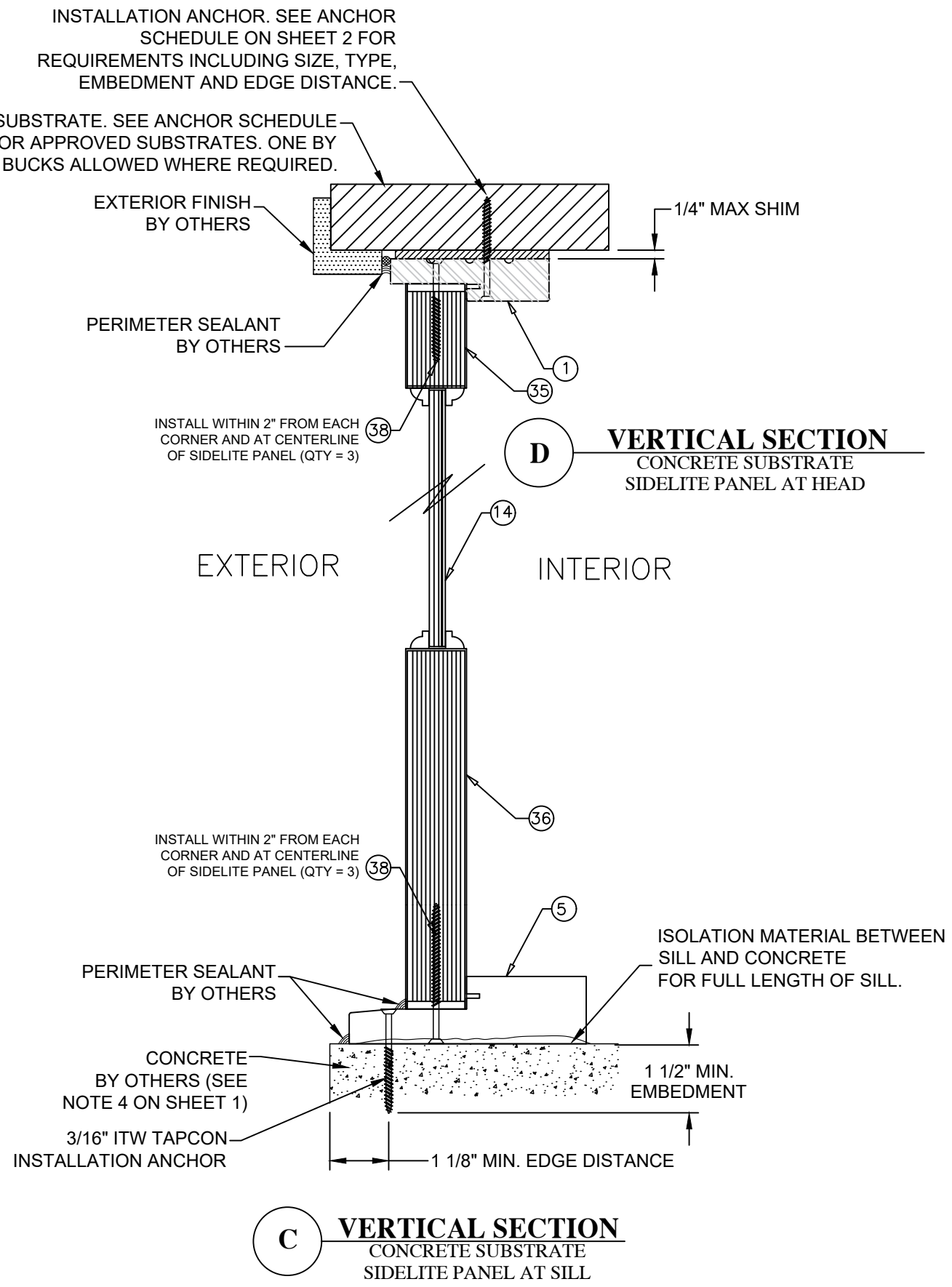
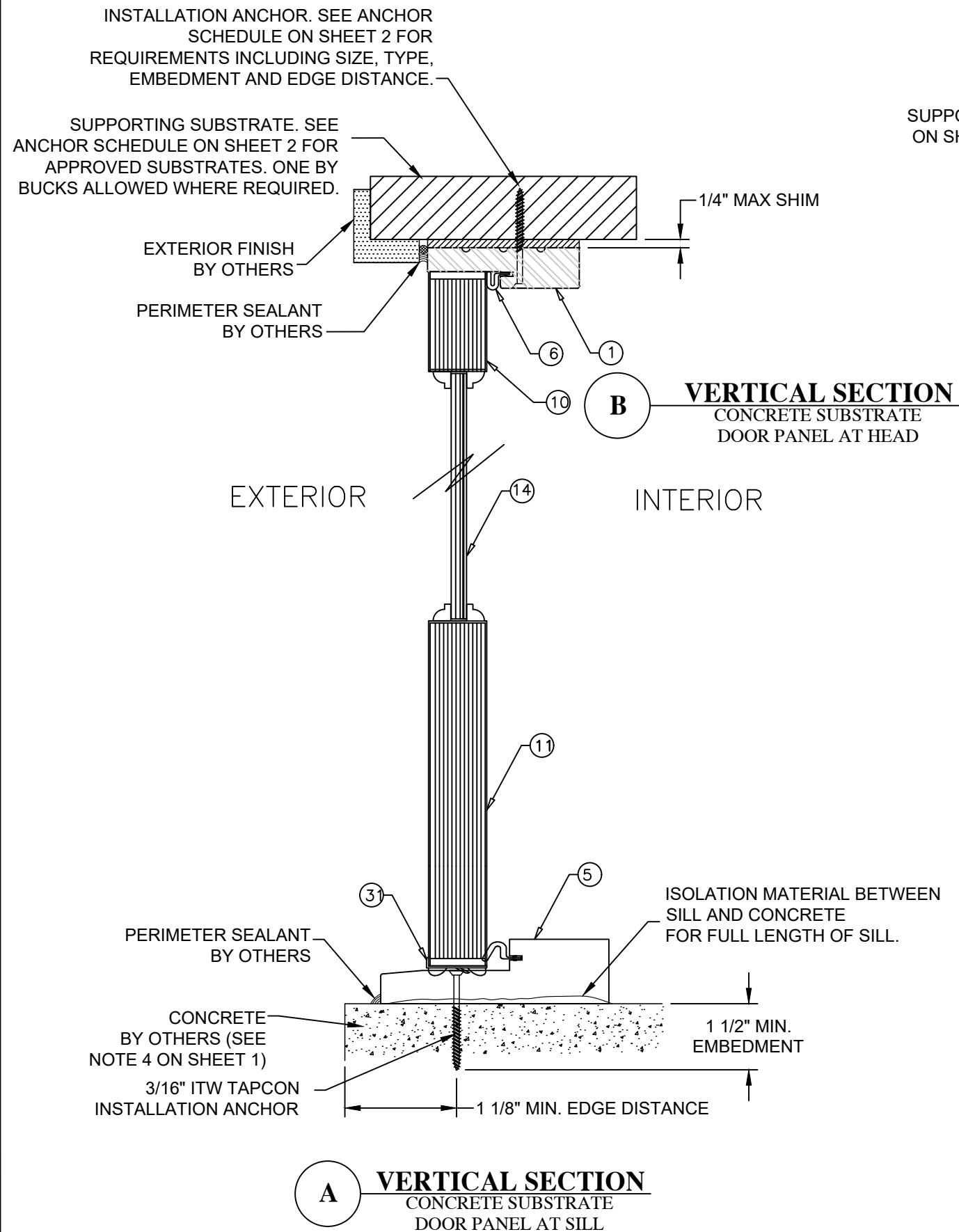

PROJECT NO. 421-0102

REV	DESCRIPTION	DATE	BY

SIMPSON DOOR COMPANY  
400 SIMPSON AVE.  
MCCLEARY, WA 98557

TITLE: HIGH IMPACT WOOD OUTSWING DOORS W/VO SIDELITES/TRANSOMS  
VERTICAL SECTIONS - WOOD SILL

PREPARED BY: RJA  
SCALE: N.T.S.  
DATE: 6/18/21  
DRAWING NO.: SIMP0027  
SHEET: 10 OF 20

Phone: 321.690.1788  
Fax: 321.690.1789  
Email: info@gdc-corp.com

Robert J. Amoruso, P.E.  
Florida P.E. No. 49752

INSTALLATION ANCHOR. SEE ANCHOR SCHEDULE ON SHEET 2 FOR REQUIREMENTS INCLUDING SIZE, TYPE, EMBEDMENT AND EDGE DISTANCE.

SUPPORTING SUBSTRATE. SEE ANCHOR SCHEDULE ON SHEET 2 FOR APPROVED SUBSTRATES. ONE BY BUCKS ALLOWED WHERE REQUIRED.

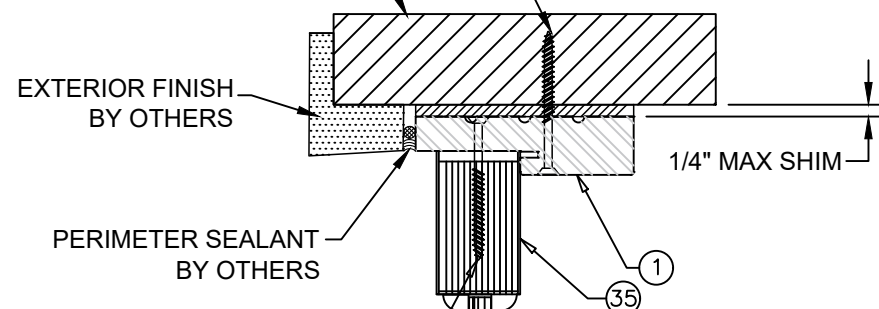

INSTALL WITHIN 2" FROM EACH CORNER AND AT 12" ON CENTER

EXTERIOR INTERIOR

INSTALL WITHIN 2" FROM EACH CORNER AND AT 12" ON CENTER

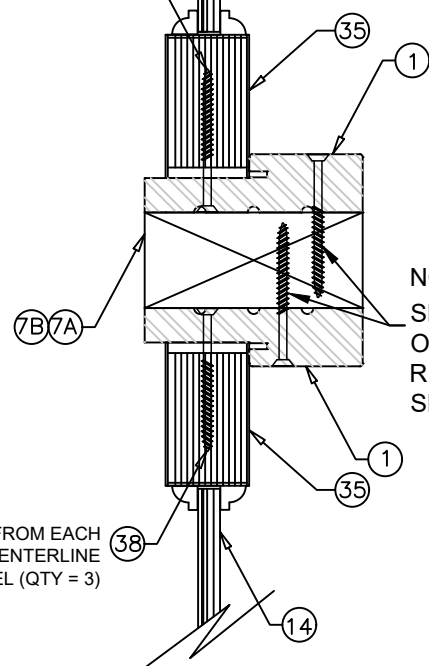

INSTALL WITHIN 2" FROM EACH CORNER AND AT CENTERLINE OF SIDELITE PANEL (QTY = 3)

NO. 10 WOOD SCREW (ITEM NO. 37) SPACED 3 1/2" MAX. FROM END AND 9" MAX. ON CENTER THEREAFTER. STAGGER AS REQUIRED TO MAINTAIN 3/4" MIN. SPACING BETWEEN ADJACENT SCREWS.

**B** VERTICAL SECTION  
VARIOUS SUBSTRATES  
TRANSOM AND  
DOOR PANEL AT HEAD

INSTALLATION ANCHOR. SEE ANCHOR SCHEDULE ON SHEET 2 FOR REQUIREMENTS INCLUDING SIZE, TYPE, EMBEDMENT AND EDGE DISTANCE.

SUPPORTING SUBSTRATE. SEE ANCHOR SCHEDULE ON SHEET 2 FOR APPROVED SUBSTRATES. ONE BY BUCKS ALLOWED WHERE REQUIRED.

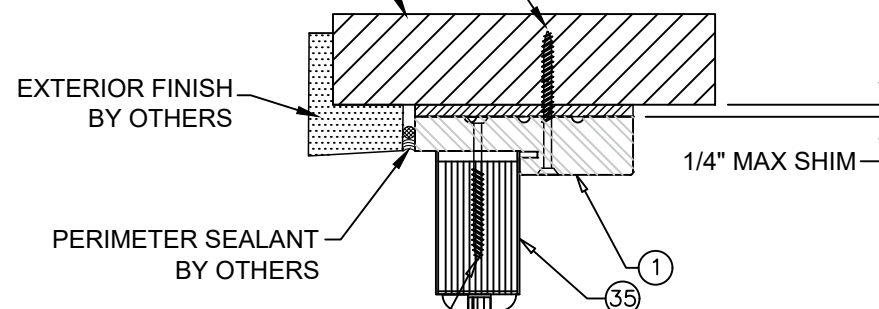

INSTALL WITHIN 2" FROM EACH CORNER AND AT 12" ON CENTER

EXTERIOR INTERIOR

INSTALL WITHIN 2" FROM EACH CORNER AND AT 12" ON CENTER

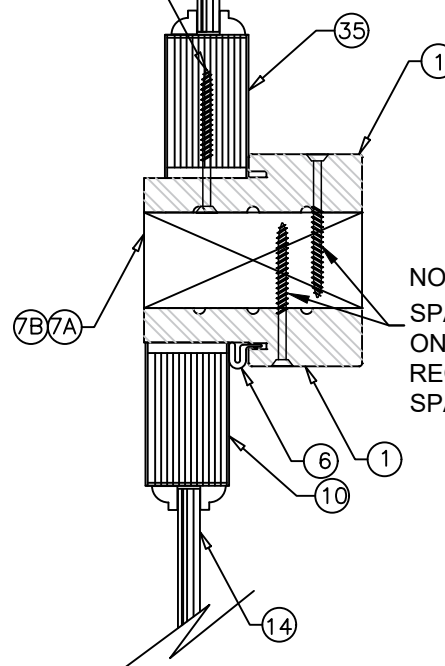

NO. 10 WOOD SCREW (ITEM NO. 37) SPACED 3 1/2" MAX. FROM END AND 9" MAX. ON CENTER THEREAFTER. STAGGER AS REQUIRED TO MAINTAIN 3/4" MIN. SPACING BETWEEN ADJACENT SCREWS.

**D** VERTICAL SECTION  
VARIOUS SUBSTRATES  
TRANSOM AND  
SIDELITE PANEL AT HEAD

PROJECT NO. 421-0102

SIMPSON DOOR COMPANY  
400 SIMPSON AVE.  
MCCLEARY, WA 98557

TITLE: HIGH IMPACT WOOD OUTSWING DOORS W/WO SIDELITES/TRANSOMS  
VERTICAL SECTIONS - TRANSOM

DATE:	6/18/21
DRAWING NO.:	SIMP0027
SHEET:	11 OF 20
DRAWN BY:	RJA
SCALE:	N.T.S.
REV:	---

REV	DESCRIPTION	DATE	BY

Robert J. Amoruso, P.E.  
Florida P.E. No. 49752



INSTALLATION ANCHOR. SEE ANCHOR SCHEDULE ON SHEET 2 FOR REQUIREMENTS INCLUDING SIZE, TYPE, EMBEDMENT AND EDGE DISTANCE.

SUPPORTING SUBSTRATE. SEE ANCHOR SCHEDULE ON SHEET 2 FOR APPROVED SUBSTRATES. ONE BY BUCKS ALLOWED WHERE REQUIRED.

EXTERIOR FINISH BY OTHERS

1/4" MAX SHIM

1/4" MAX SHIM

INSTALLATION ANCHOR. SEE ANCHOR SCHEDULE ON SHEET 2 FOR REQUIREMENTS INCLUDING SIZE, TYPE, EMBEDMENT AND EDGE DISTANCE.

SUPPORTING SUBSTRATE. SEE ANCHOR SCHEDULE ON SHEET 2 FOR APPROVED SUBSTRATES. ONE BY BUCKS ALLOWED WHERE REQUIRED.

EXTERIOR FINISH BY OTHERS

INTERIOR  
EXTERIOR

INSTALL WITHIN 2" FROM EACH CORNER AND 12" ON CENTER MAX. THEREAFTER

PERIMETER SEALANT BY OTHERS

**G** HORIZONTAL SECTION  
WOOD SUBSTRATE  
SIDELITE PANEL AT JAMB

**H** HORIZONTAL SECTION  
WOOD SUBSTRATE  
SIDELITE PANEL AT JAMB

ITEM 37 - 3-1/2" END DISTANCE AT HEAD & SILL, 12" ON CENTER MAX. (TYPICAL)

ITEM 37 - 3-1/2" END DISTANCE AT HEAD & SILL, 12" ON CENTER MAX. (TYPICAL)

INSTALL WITHIN 2" FROM EACH CORNER AND 12" ON CENTER MAX. THEREAFTER

INSTALL WITHIN 2" FROM EACH CORNER AND 12" ON CENTER MAX. THEREAFTER

**I** HORIZONTAL SECTION  
DOUBLE FRAME MULLION

**J** HORIZONTAL SECTION  
ASTRAGAL

**K** HORIZONTAL SECTION  
DOUBLE FRAME MULLION

PROJECT NO. 421-0102

SIMPSON DOOR COMPANY  
400 SIMPSON AVE.  
MCCLEARY, WA 98557

TITLE: HIGH IMPACT WOOD OUTSWING DOORS W/WO SIDELITES/TRANSOMS  
HORIZONTAL SECTIONS - OXO

PREPARED BY: RJA

SCALE: N.T.S.

DATE: 6/18/21

DRAWING NO: SIMP0027

SHEET: 12 OF 20

DESCRIPTION

BY

DATE

Robert J. Amoruso, P.E.  
Florida P.E. No. 49752

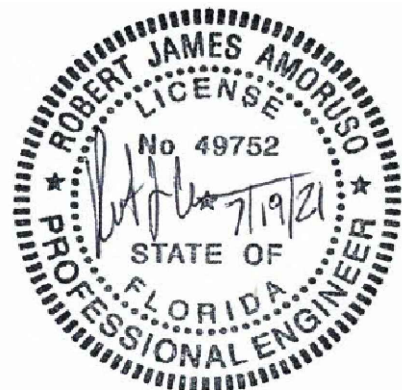



INSTALLATION ANCHOR. SEE ANCHOR SCHEDULE ON SHEET 2 FOR REQUIREMENTS INCLUDING SIZE, TYPE, EMBEDMENT AND EDGE DISTANCE.

SUPPORTING SUBSTRATE. SEE ANCHOR SCHEDULE ON SHEET 2 FOR APPROVED SUBSTRATES. ONE BY BUCKS ALLOWED WHERE REQUIRED.

EXTERIOR FINISH BY OTHERS

PERIMETER SEALANT BY OTHERS

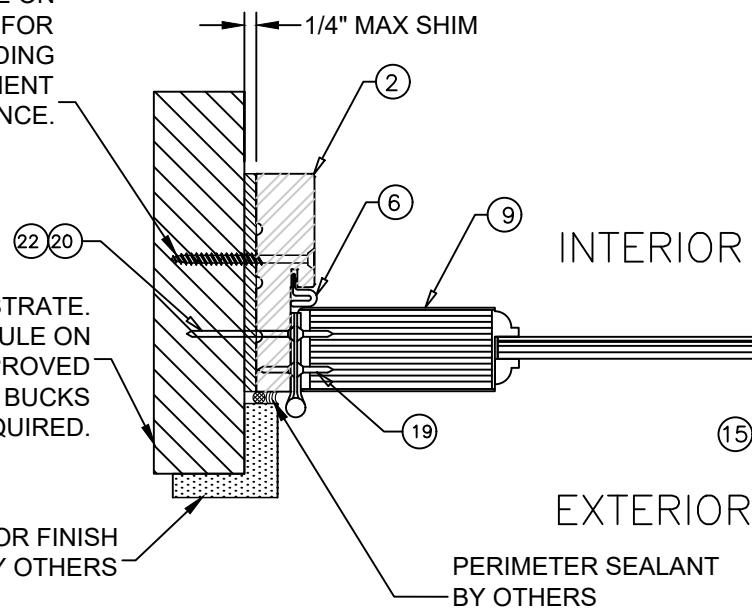

**L** **HORIZONTAL SECTION**  
WOOD SUBSTRATE  
DOOR PANEL AT JAMB

INSTALLATION ANCHOR. SEE ANCHOR SCHEDULE ON SHEET 2 FOR REQUIREMENTS INCLUDING SIZE, TYPE, EMBEDMENT AND EDGE DISTANCE.

SUPPORTING SUBSTRATE. SEE ANCHOR SCHEDULE ON SHEET 2 FOR APPROVED SUBSTRATES. ONE BY BUCKS ALLOWED WHERE REQUIRED.

EXTERIOR FINISH BY OTHERS

PERIMETER SEALANT BY OTHERS

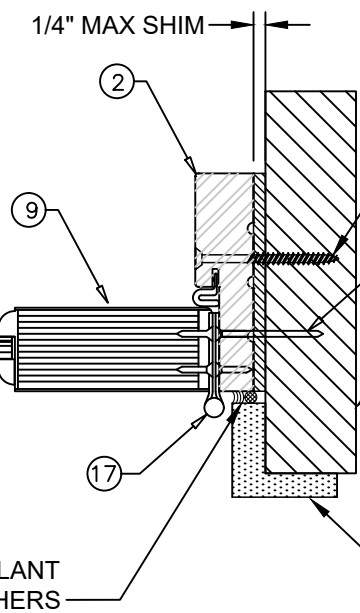

**M** **HORIZONTAL SECTION**  
WOOD SUBSTRATE  
DOOR PANEL AT JAMB

INSTALLATION ANCHOR. SEE ANCHOR SCHEDULE ON SHEET 2 FOR REQUIREMENTS INCLUDING SIZE, TYPE, EMBEDMENT AND EDGE DISTANCE.

SUPPORTING SUBSTRATE. SEE ANCHOR SCHEDULE ON SHEET 2 FOR APPROVED SUBSTRATES. ONE BY BUCKS ALLOWED WHERE REQUIRED.

EXTERIOR FINISH BY OTHERS

PERIMETER SEALANT BY OTHERS

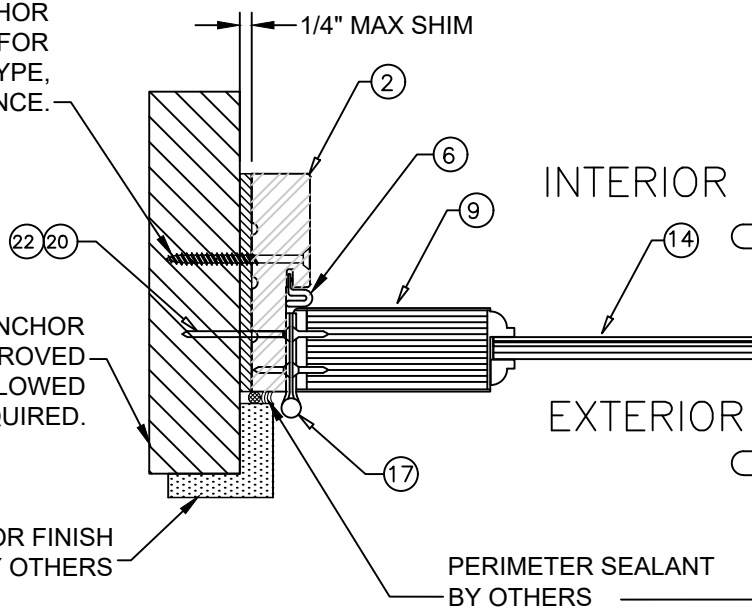

**L** **HORIZONTAL SECTION**  
WOOD SUBSTRATE  
DOOR PANEL AT JAMB

INSTALLATION ANCHOR. SEE ANCHOR SCHEDULE ON SHEET 2 FOR REQUIREMENTS INCLUDING SIZE, TYPE, EMBEDMENT AND EDGE DISTANCE.

SUPPORTING SUBSTRATE. SEE ANCHOR SCHEDULE ON SHEET 2 FOR APPROVED SUBSTRATES. ONE BY BUCKS ALLOWED WHERE REQUIRED.

EXTERIOR FINISH BY OTHERS

PERIMETER SEALANT BY OTHERS

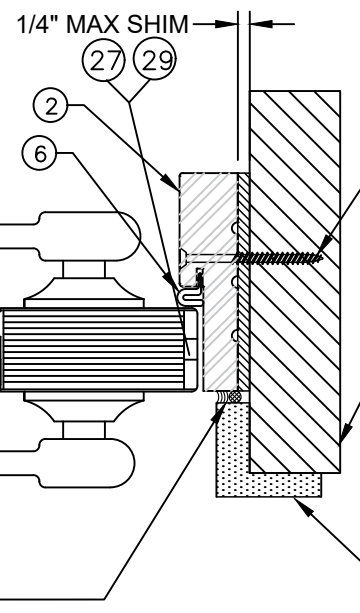

**N** **HORIZONTAL SECTION**  
WOOD SUBSTRATE  
DOOR PANEL AT JAMB

PROJECT NO. 421-0102

REV	DESCRIPTION	DATE	BY

**SIMPSON DOOR COMPANY**  
400 SIMPSON AVE.  
MCCLEARY, WA 98557

TITLE: HIGH IMPACT WOOD OUTSWING DOORS W/ WOOD SIDELITES/TRANSOMS  
HORIZONTAL SECTIONS - XX AND X

PREPARED BY: RJA  
SCALE: N.T.S.  
REV: ---

DATE: 6/18/21  
DRAWING NO: SIMP0027  
SHEET: 13 OF 20

Phone: 321.690.1788  
Fax: 321.690.1789  
Email: info@pdc-corp.com

Robert J. Amoruso, P.E.  
Florida P.E. No. 49752

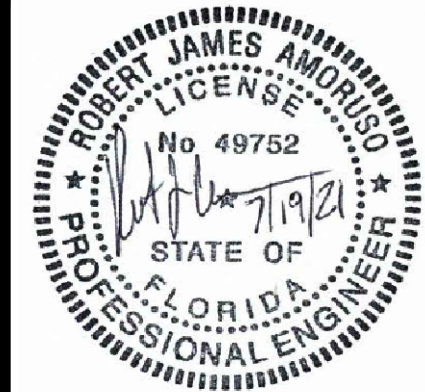

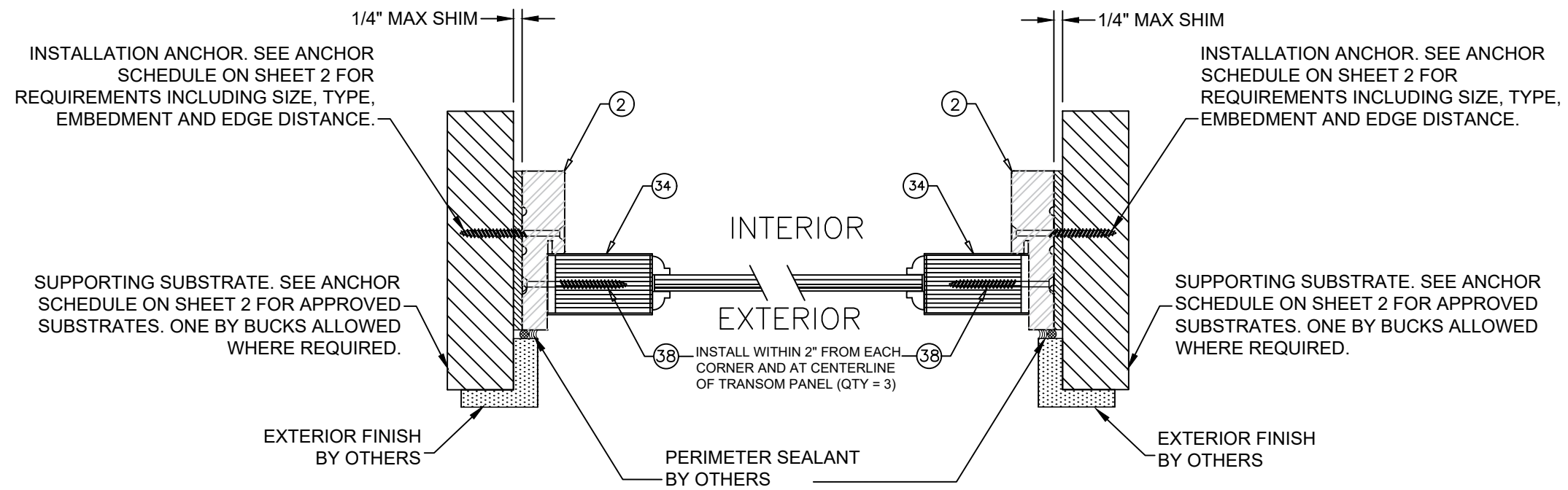

**O** **HORIZONTAL SECTION**  
VARIOUS SUBSTRATES  
TRANSOM PANEL AT JAMB

**P** **HORIZONTAL SECTION**  
VARIOUS SUBSTRATES  
TRANSOM PANEL AT JAMB

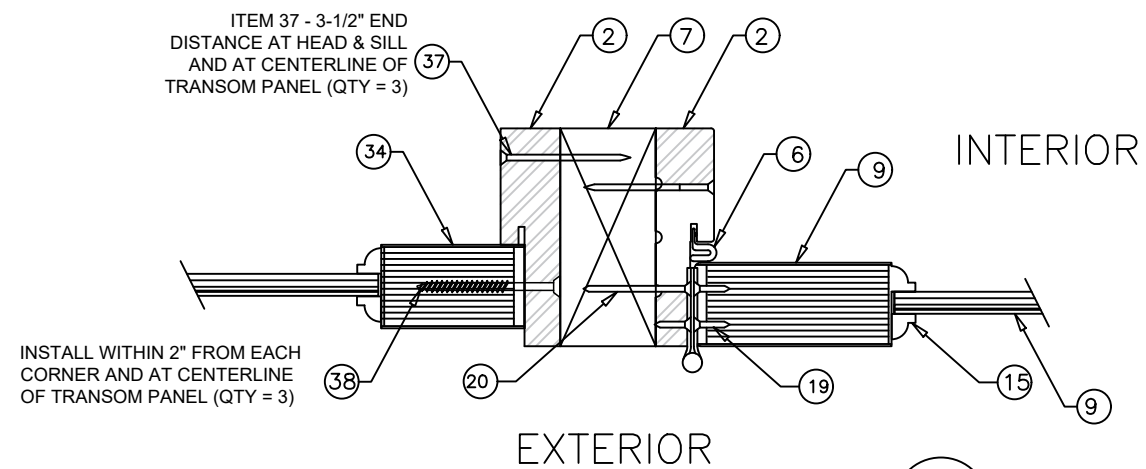

**Q** **HORIZONTAL SECTION**  
TRANSOM PANEL MULLION

PROJECT NO. 421-0102

REV	DESCRIPTION	DATE	BY

**SIMPSON DOOR COMPANY**  
400 SIMPSON AVE.  
MCCLEARY, WA 98557

TITLE: HIGH IMPACT WOOD OUTSWING DOORS W/WO SIDELITES/TRANSOMS  
HORIZONTAL SECTIONS - TRANSOM

PREPARED BY: RJA  
SCALE: N.T.S.  
REV: ---

DATE: 6/18/21  
DRAWING NO: SIMP0027  
SHEET: 14 OF 20

PTC Product Design Group, LLC  
PO Box 320775  
Lenoir, NC 27539  
Phone: 321.690.1788  
Fax: 321.690.1789  
Email: info@pdc-corp.com  
FBPE C.A. NO. 25595

Robert J. Amoruso, P.E.  
Florida P.E. No. 49752



ITEM	DESCRIPTION	QTY	COMMENTS
1	UNIT HEAD EURO JAMB (KERFED)	1	1-7/32" x 4-9/16" DOUGLAS FIR OR EQUIV
2	UNIT SIDE EURO JAMB (KERFED)	2	1-7/32" x 4-9/16" DOUGLAS FIR OR EQUIV
3			
4	ONE (1) PC T-ASTRIGAL	1	1-3/4" x 3-1/2" DOUGLAS FIR OR EQUIV
5	MAHOGANY EURO SILL - OUTSWING	1	1-3/8" x 7-13/16" MAHOGANY OR EQUIV.
	OUTSILL SILL	1	1-3/8" x 7-13/16" ALUMINUM/COMPOSITE
6	LONG REACH COMPRESSION WEATHERSTRIP		QEBD650 OR EQUIVALENT
7	VERTICAL MULL		2-1/4" X 4-1/2" DOUGLAS FIR OR EQUIV
7A	HORIZONTAL MULL (107" MAX. LENGTH)		2-1/4" X 4-1/2" DOUGLAS FIR OR EQUIV
7B	HORIZONTAL MULL (GREATER THAN 107" LENGTH)		2-1/4" X 4-1/2" DOUGLAS FIR/STEEL FLITCH BEAM
8	GLAZING SEALANT		DOW 995
9	DOOR STILE (LVL CORE)	2	2-1/4" x 5-3/8" DOUGLAS FIR OR EQUIV
10	DOOR TOP RAIL	2	2-1/4" x 5-3/8" DOUGLAS FIR OR EQUIV
11	DOOR BOTTOM RAIL (LVL CORE)	2	2-1/4" x 10-7/8" DOUGLAS FIR OR EQUIV
12	DOOR GLAZED LOCK RAIL	1	2-1/4" x 7-1/2" DOUGLAS FIR OR EQUIV
13	IMPACT PANEL		MARINE PLYWOOD CORE
14	DOOR GLASS	2	11/16" Impact Glass
15	STOP FOR GLASS		1/2" x 5/8" x LF DOUGLAS FIR OR EQUIV
16	GLAZING STOP FASTENER	30	DUO-FAST DA17EPB 1 1/2" FINISH NAIL OR EQUIV.
17	4-1/2 X 4-1/2 BALL BEARING HINGE	8	SGS BB3000
18	4-1/2 X 4-1/2 BALL BEARING HINGE	2	SGS BB3000 (NRP)
19	#9 x 3/4" FHWS	40	4 / HINGE
20	#9 x 2-1/4" FHWS	40	4 / HINGE - USED FOR DOOR HINGE INSTALLATION
21	12" SURFACE BOLT INCLUDING HARDWARE	4	IUES SB360-12 HD
22	3/16" ITW TAPCON <small>LENGTH AS REQ'D TO OBTAIN 1" EMB. INTO CMU OR 1-1/2" EMB. INTO CONCRETE.</small>	AS REQ'D	USED FOR XX AND X DOOR HINGE INSTALLATION
23	#7 x 2-1/4" FHWS (HARDENED)	6	USED FOR MULL POSTS AND SIDE JAMBS
24	#9 x 2-1/2" FHWS (HARDENED)	19	UNIT CONSTRUCTION AS NOTED
25	ENDURA DBSH SEAL	AS REQ'D	BOTTOM OF SIDELITE PANEL
26	#10 x 2-1/2" FHWS	4	STRIKE SCREWS IN HEADER AND SILL
27	5 PT LOCKSET HARDWARE (ACTIVE)		Trillanium
28	5 PT LOCKSET HARDWARE (INACTIVE)		Trillanium
29	5 PT LOCKSET INC. HARDWARE (ACTIVE)	1	HOPPE HLS9000 OR EQUIVALENT
30	5 PT LOCKSET INC. HARDWARE (INACTIVE)	1	HOPPE HLS9000 OR EQUIVALENT
31	ENDURA DBS214 SEAL	AS REQ'D	BOTTOM OF DOOR PANEL
32	ACTIVE REINFORCEMENT PLATE	2	STAINLESS STEEL
33	INACTIVE REINFORCEMENT PLATE	2	STAINLESS STEEL
34	SIDELITE/TRANSOM STILE	2	1-3/4" x 3-1/2" DOUGLAS FIR OR EQUIV
35	SIDELITE TOP & TRANSOM TOP/BOTTOM RAILS	2	1-3/4" x 3-1/2" DOUGLAS FIR OR EQUIV
36	SIDELITE BOTTOM RAIL	2	1-3/4" x 11-3/8" DOUGLAS FIR OR EQUIV
37	#10 x 3" FHWS (HARDENED)	40	DOOR AND SIDELITE/TRANSOM JAMB TO MULLION
38	#9 x 2-1/2" FHWS	48	SIDELITE/TRANSOM PANEL TO FRAME HEAD AND JAMBS

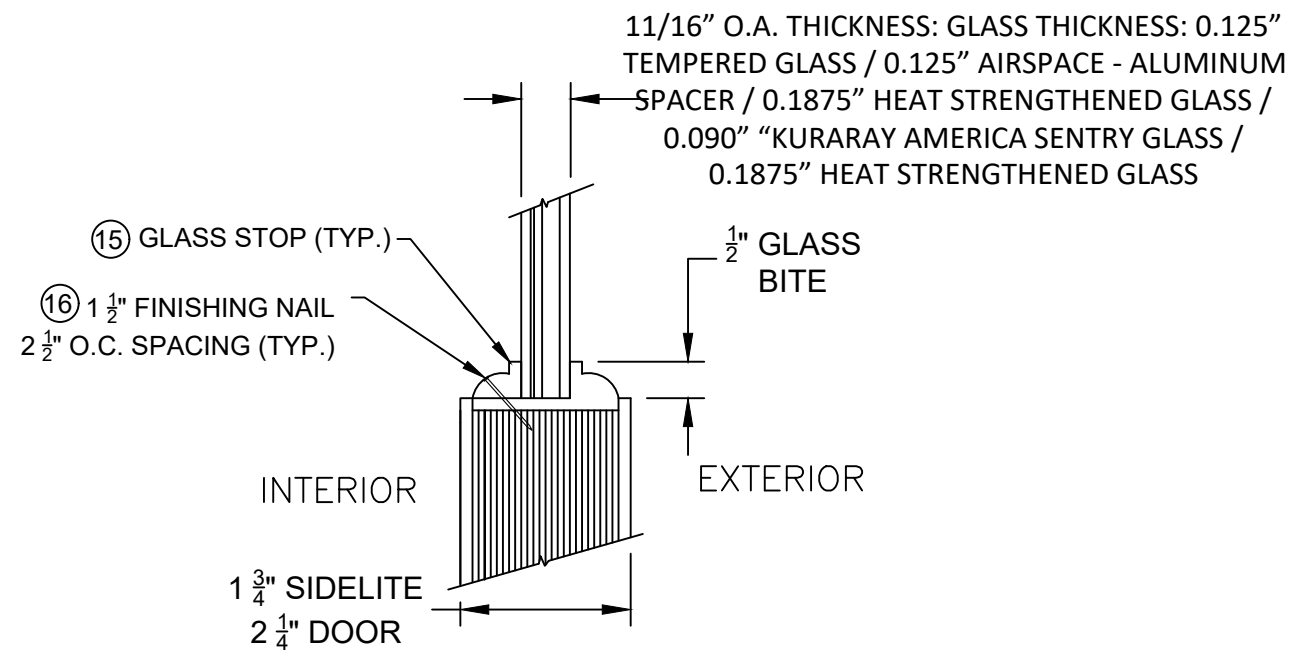

**GLAZING DETAIL A**  
LAMINATED IG IMPACT GLAZING  
DOW 995 GLAZING SEALANT

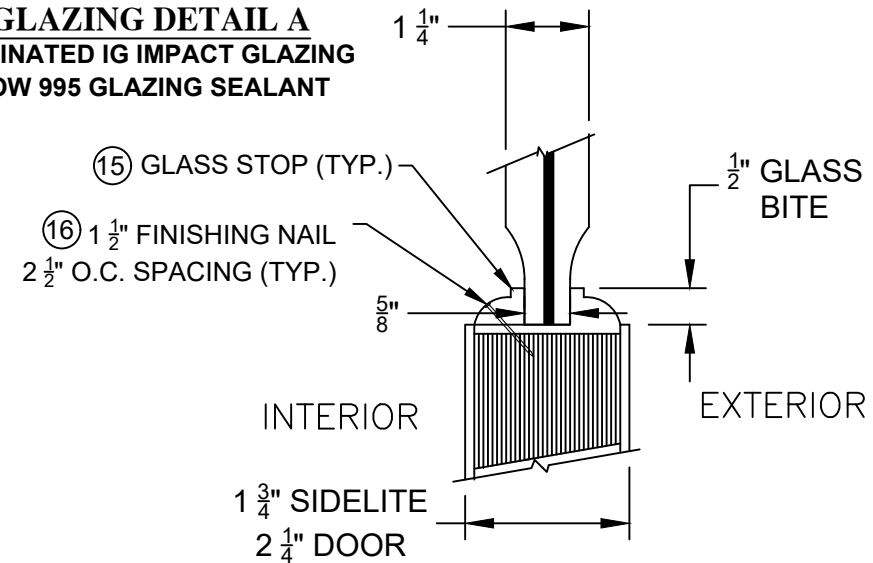

**GLAZING DETAIL B**  
RAISED IMPACT PANEL  
DOW 995 GLAZING SEALANT

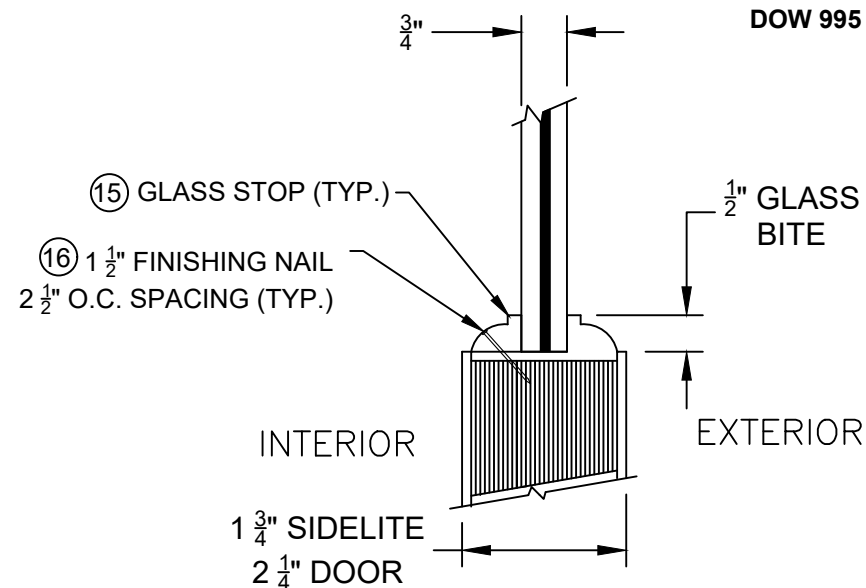

**GLAZING DETAIL C**  
FLAT IMPACT PANEL  
DOW 995 GLAZING SEALANT

PROJECT NO. 421-0102

SIMPSON DOOR COMPANY  
400 SIMPSON AVE.  
MCCLEARY, WA 98557

TITLE: HIGH IMPACT WOOD OUTSWING DOORS W/ WOOD SIDELITES/TRANSOMS  
BILL OF MATERIALS / GLAZING DETAILS

DATE:	6/18/21
DRAWING NO.:	SIMP0027
SHEET:	15 OF 20
DATE:	
DESCRIPTION:	
REV:	

PREPARED BY: RJA  
SCALE: N.T.S.  
REV: ---  
PTC Product Design Group, LLC  
PO Box 320775  
Lynchburg, VA 24097-0775  
FBPE GA. NO. 25595  
Phone: 321.690.1788  
Fax: 321.690.1789  
Email: info@ptc-corp.com

Robert J. Amoroso, P.E.  
Florida P.E. No. 49752

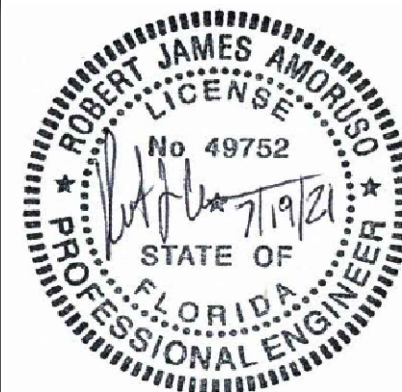

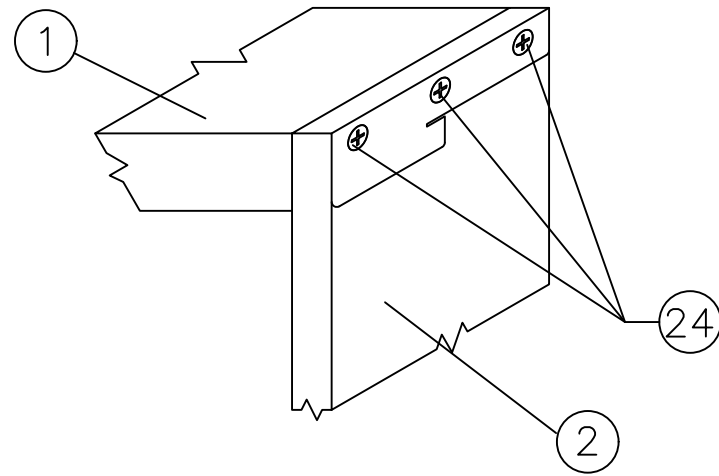

SIDE JAMB ATTACHMENT TO HEAD JAMB

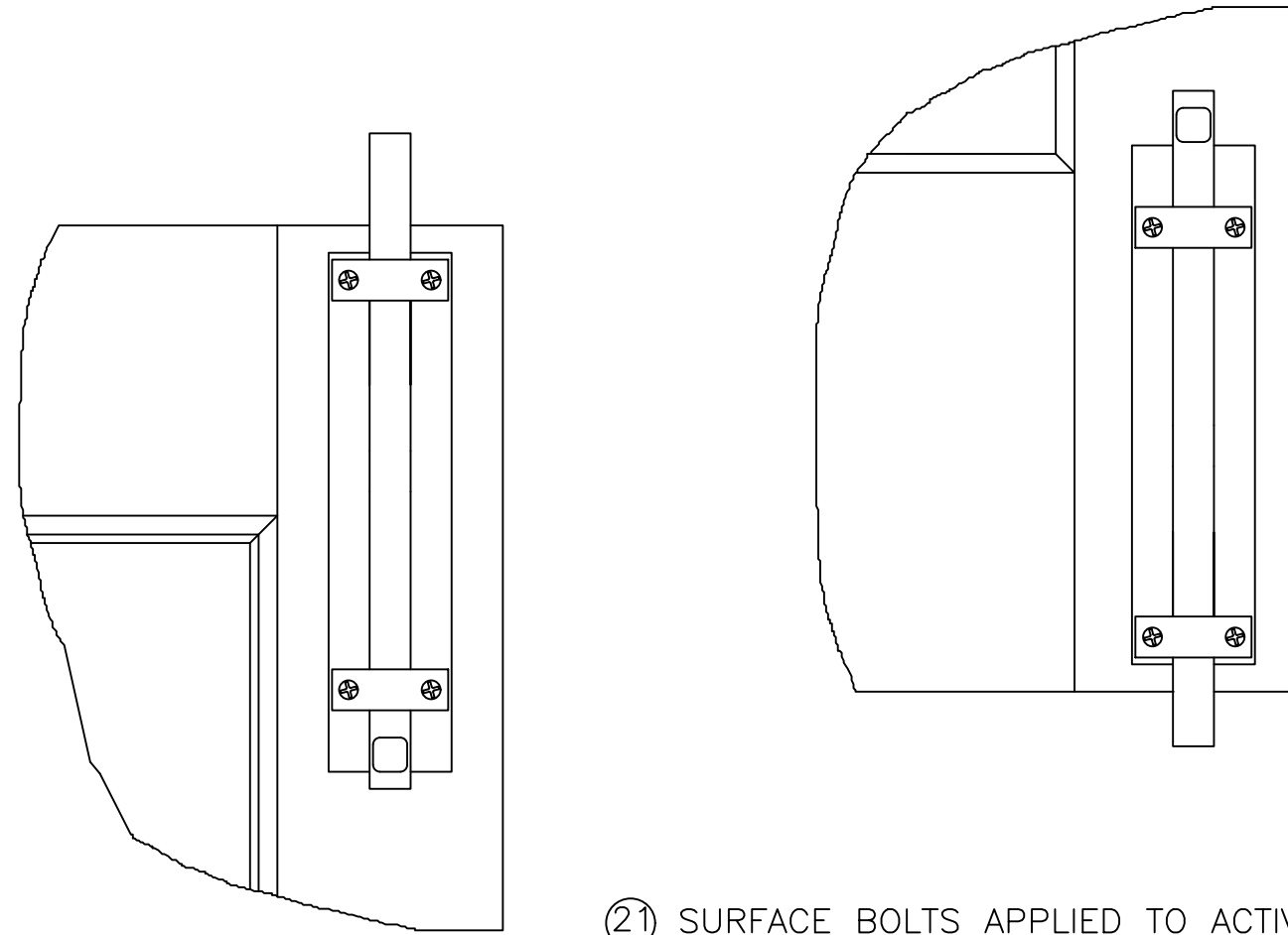

②1 SURFACE BOLTS APPLIED TO ACTIVE AS WELL AS INACTIVE DOORS

②1 SURFACE BOLTS APPLIED TO ACTIVE AS WELL AS INACTIVE DOORS

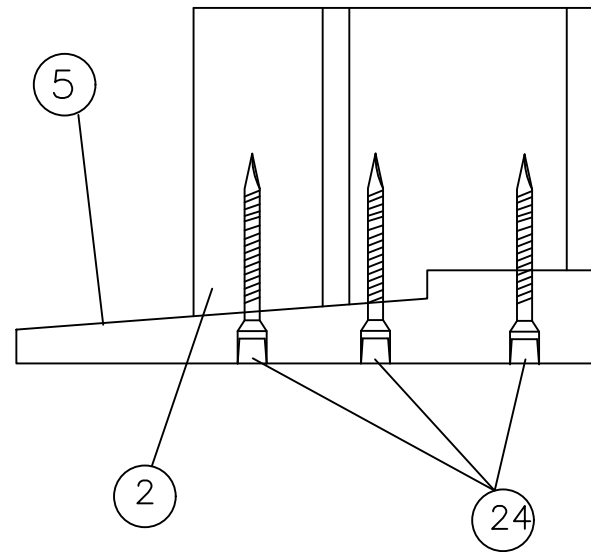

TOP MOUNT JAMB ATTACHMENT TO THRESHOLD

DEMENSIONS  
 Bar: 3/4" Wide x 3/4" Thick  
 Overall Width: 2-1/32"  
 Overall Projection: 2-1/16"  
 Top Strike 1-1/2" Wide x 1-1/2" Long x 3/16" Thick  
 Optional Mortise Strike: 1-5/8" Wide x 3-1/2" Long x 1/8" Thick

PROJECT NO. 421-0102		REV	DESCRIPTION	DATE	BY

**SIMPSON DOOR COMPANY**  
 400 SIMPSON AVE.  
 MCCLEARY, WA 98557

TITLE: HIGH IMPACT WOOD OUTSWING DOORS W/WO SIDELITES/TRANSOMS  
 END CONNECTION & SURFACE BOLT DETAILS

PREPARED BY: RJA  
 DATE: 6/18/21  
 DRAWING NO.: SIMP0027  
 SCALE: N.T.S.  
 SHEET: 16 OF 20

**PIE**  
 PTC Product Design Group, LLC  
 PO Box 320775  
 Lenexa, KS 66247-0775  
 Phone: 321.690.1788  
 Fax: 321.690.1789  
 Email: info@ptc-corp.com  
 FBPE C.A. NO. 25535

Robert J. Amoruso, P.E.  
Florida P.E. No. 49752

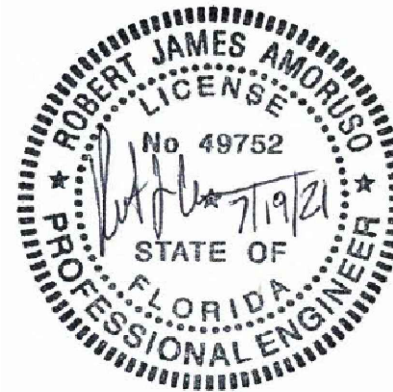



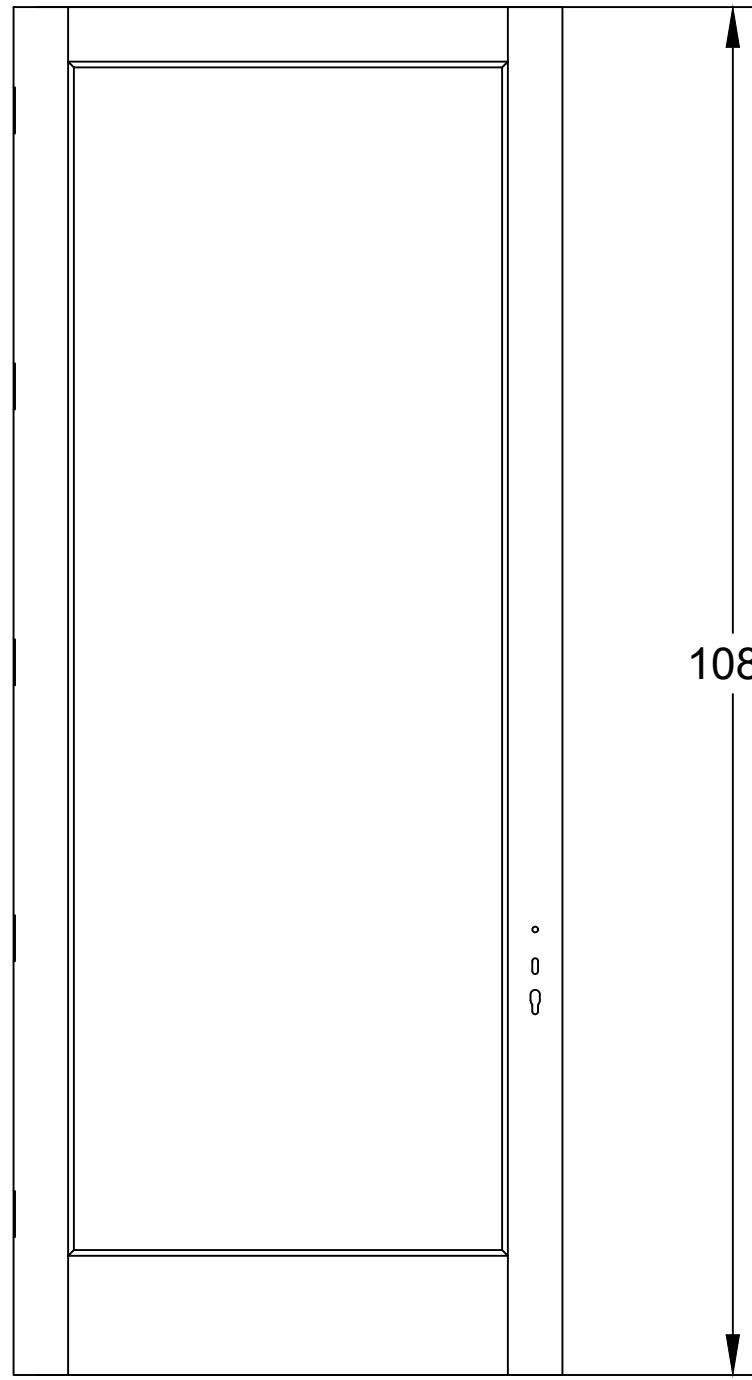
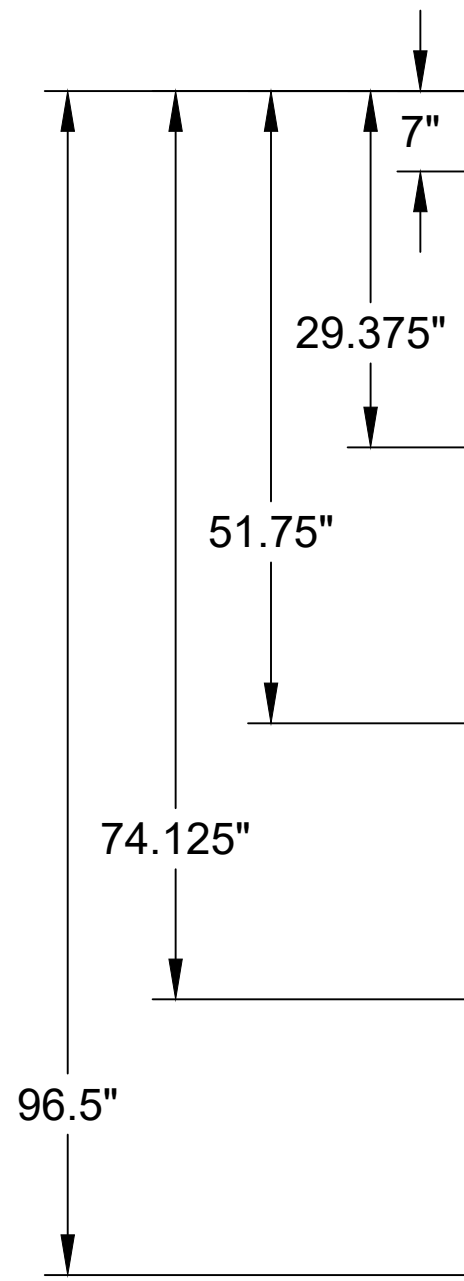

42"

TOP OF HINGE (ITEM 17 OR 18) LOCATIONS

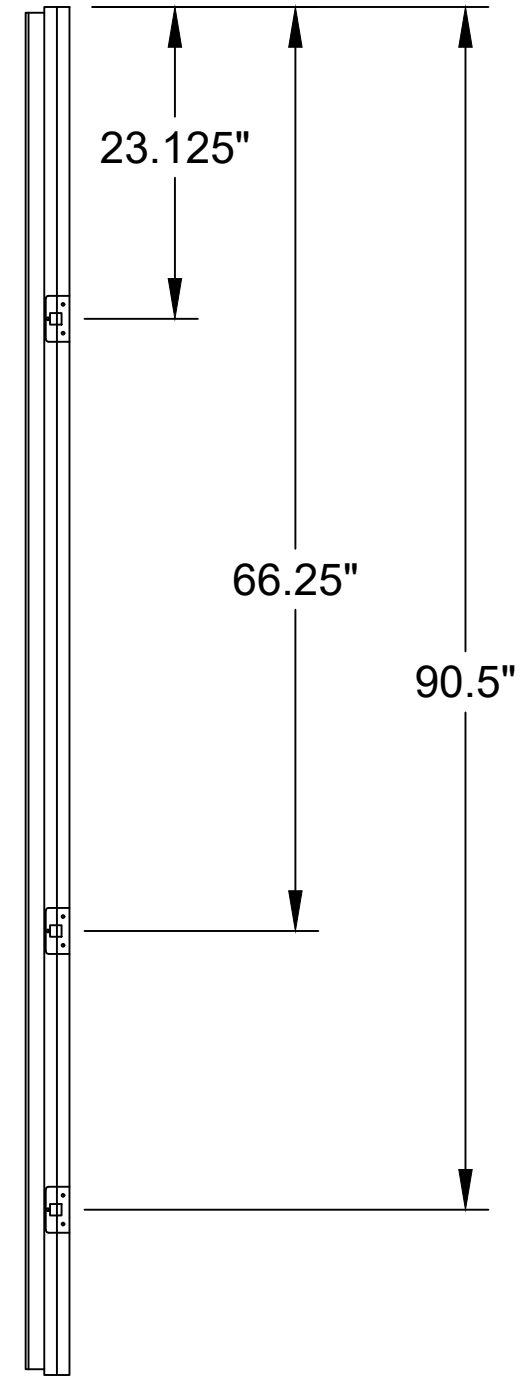

LOCKSET LOCKING POINT (ITEM 27, 28, 29 & 30) LOCATIONS

PROJECT NO. 421-0102		REV	DESCRIPTION	DATE	BY

**SIMPSON DOOR COMPANY**  
 400 SIMPSON AVE.  
 MCCLEARY, WA 98557

TITLE: HIGH IMPACT WOOD OUTSWING DOORS W/WO SIDELITES/TRANSOMS  
 HINGE AND LOCKSET DETAILS

PREPARED BY:	DATE:
DRAWN BY: RJA	6/18/21
SCALE: N.T.S.	DRAWING NO: SIMP0027
REV: ---	SHEET: 17 OF 20

 PDC Product Design Group, LLC  
 PO Box 320775  
 Lenexa, KS 66207-0775  
 Phone: 321.690.1788  
 Fax: 321.690.1789  
 Email: info@pdc-corp.com  
 FBPE C.A. NO. 25595

Robert J. Amoruso, P.E.  
 Florida P.E. No. 49752

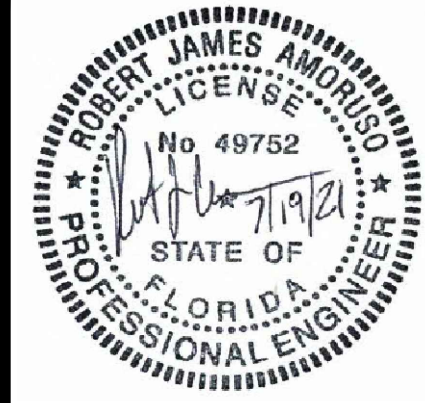

# MULLION DETAILS

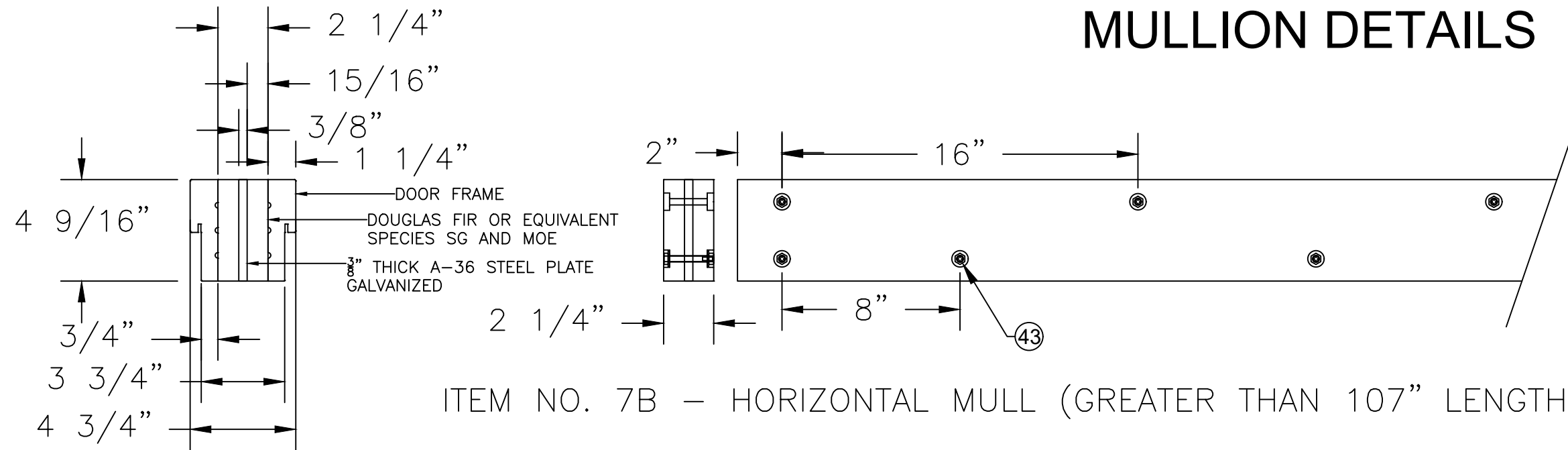

ITEM NO. 7B - HORIZONTAL MULL (GREATER THAN 107" LENGTH)

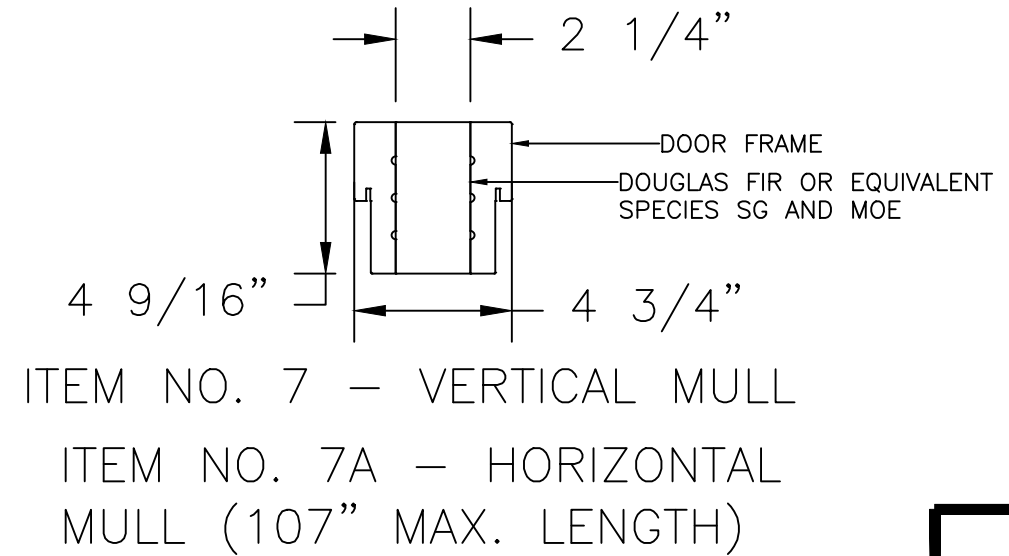
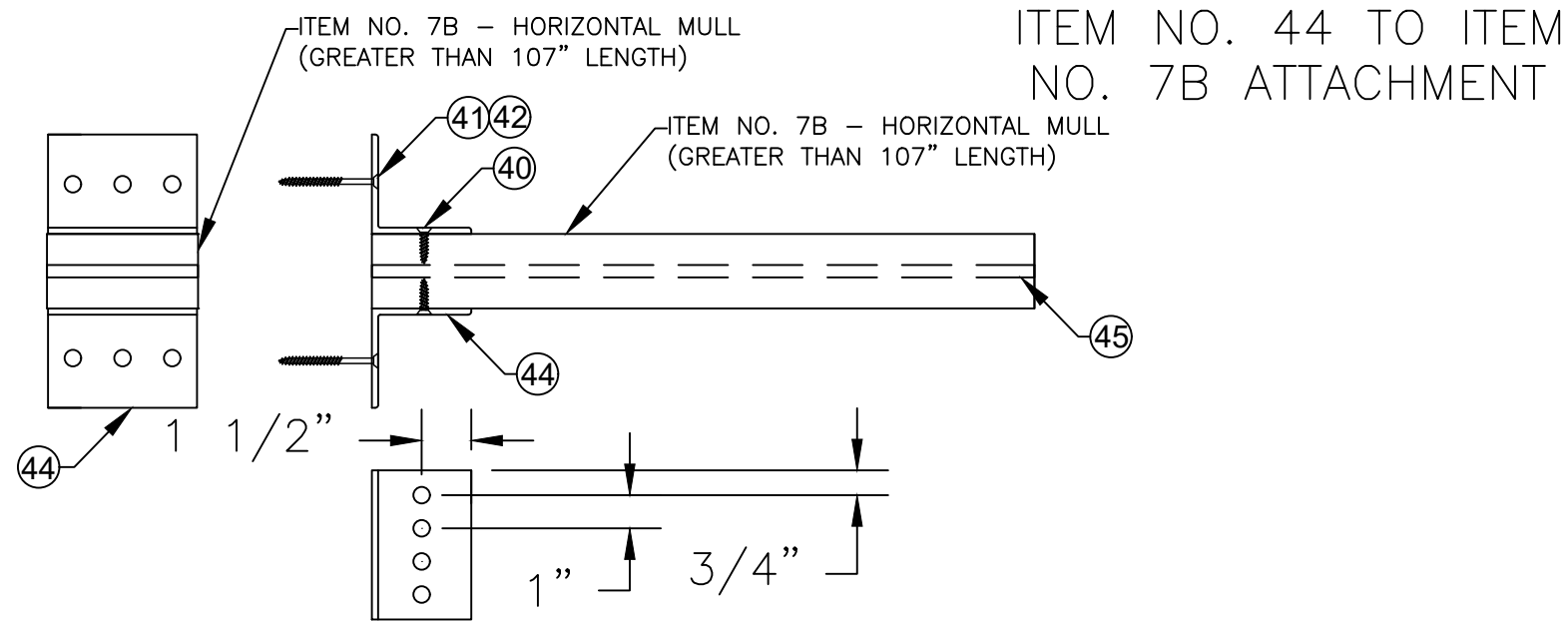

ITEM NO. 7 - VERTICAL MULL  
ITEM NO. 7A - HORIZONTAL MULL (107" MAX. LENGTH)

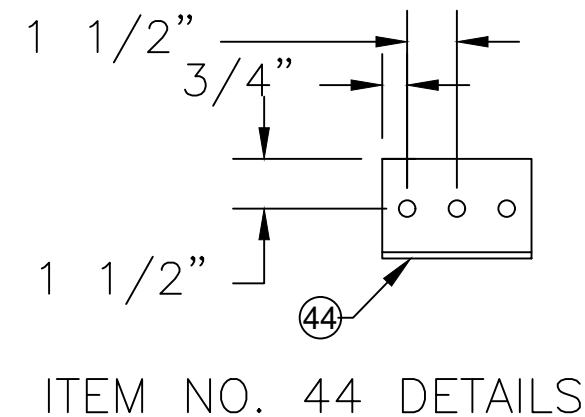
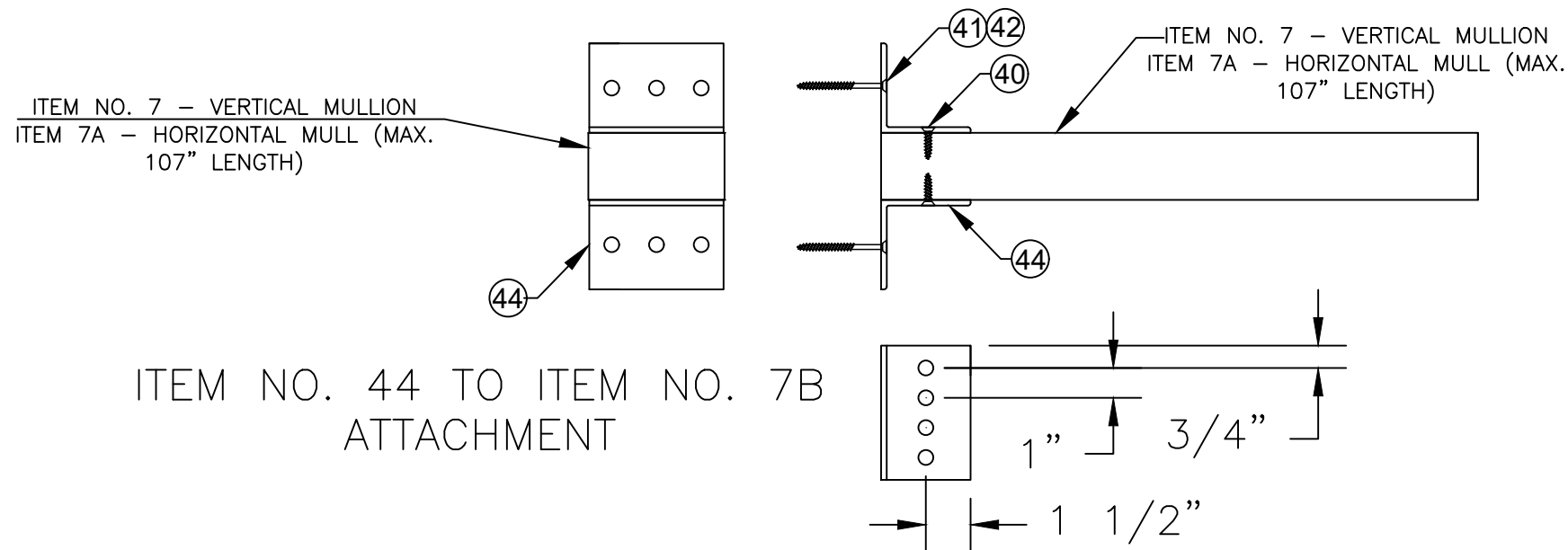

ITEM NO. 44 DETAILS

PROJECT NO. 421-0102

SIMPSON DOOR COMPANY 400 SIMPSON AVE. MCCLEARY, WA 98557	DATE:	6/18/21
	DRAWING NO.:	SIMP0027
TITLE: HIGH IMPACT WOOD OUTSWING DOORS W/VO SIDELITES/TRANSOMS MULLION DETAILS	SCALE:	N.T.S.
PREPARED BY:	DRWN BY:	RJA
	SCALE:	N.T.S.
	REV:	---
	SHEET:	18 OF 20

Robert J. Amoruso, P.E.  
Florida P.E. No. 49752



# MULLION DETAILS

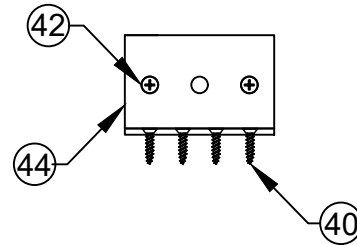

ITEM NO. 44  
CONCRETE/MASONRY  
INSTALLATION SCREWS

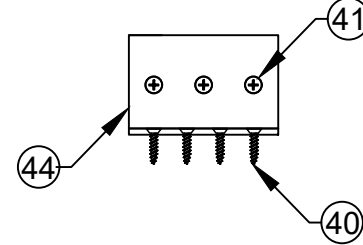

ITEM NO. 44  
WOOD FRAMING  
INSTALLATION SCREWS

## BILL OF MATERIALS - CONTINUED

ITEM NO.	DESCRIPTION	MATERIAL / MANUFACTURER / OTHER DETAILS
7	VERTICAL MULLION	DOUGLAS FIR (OR EQUIVALENT WOOD SPECIES, SG AND MOE)
7A	HORIZONTAL MULLION (107" MAX. LENGTH)	DOUGLAS FIR (OR EQUIVALENT WOOD SPECIES, SG AND MOE)
7B	HORIZONTAL MULLION (GREATER THAN 107" LENGTH)	DOUGLAS FIR (OR EQUIVALENT WOOD SPECIES, SG AND MOE) / A-36 4-9/16" X 3/8" STEEL FLITCH BEAM
40	#14 x 1" Type AB Self-Tapping Screws / Phillips / Flat Head / Steel	
41	#14 x 1 3/4" Wood Screws / Phillips / Flat Head / Steel / Zinc	LENGTH AS REQUIRED TO OBTAIN A MINIMUM 1-1/2" EMBEDMENT IN SOUTHERN PINE 2X WOOD FRAMING. EDGE DISTANCE SHALL BE 1" MINIMUM.
42	1/4" HILTI KWIK-CON II+ CONCRETE/MASONRY SCREW	LENGTH AS REQUIRED TO OBTAIN AN EMBEDMENT OF 1" MINIMUM IN MASONRY/CMU AND 1-3/4" MINIMUM IN CONCRETE. EDGE DISTANCE SHALL BE 1-1/2" MINIMUM.
43	1/2-13 x 1 3/4" Hex Machine Bolts / Steel, 1/2-13 Hex Nut / Steel and 1/2" USS Flat Washer (2)	
44	3 x 3 x 3/16" Steel Angle	A-36, length as req'd
45	4-9/16" x 3/8" Thick Steel Plate	A-36, length as req'd to match mullion length

### NOTES:

1) ALL HARDWARE, STEEL PLATES AND ANGLES SHALL BE ZINC COATED, HOT DIP GALVANIZED OR OTHERWISE PLATED TO PREVENT CORROSION.

2) To avoid splitting of wood substrates, use the following pilot holes. Item No. 40 #14 Self-Tapping Screw pilot hole shall be No. 20 drill (0.161" dia.). Item No. 41 #14 Wood Screw pilot hole shall be No. 25 drill (0.149" dia.)

## MULLION INSTALLATION DETAILS

1. SEE SHEETS 18 AND 19 FOR MULLION DETAILS AND INSTALLATION ANCHOR BILL OR MATERIALS.
2. MULLIONS FALL INTO TWO CATEGORIES
  - 2.1. VERTICAL MULLION (ITEM NO. 7)
    - 2.1.1. BETWEEN SIDELITES AND DOOR PANEL FRAMING. SEE SECTIONS I/12 AND K/12.
    - 2.1.2. BETWEEN TRANSOM PANELS WHEN TRANSOM SIZE EXCEEDS 102.125" X 25.5" PANEL/FRAME SIZE. SEE SECTION Q/14.
    - 2.1.3. THE VERTICAL MULLIONS DO NOT REQUIRE CLIPPED ENDS.
    - 2.1.4. THE VERTICAL MULLION LENGTHS CORRESPOND TO THE HEIGHT OF THE MULLED ASSEMBLY WHETHER THAT IS THE SIDELITE TO DOOR JAMBS OR TRANSOM JAMBS.
    - 2.2.3. ITEM NO. 7 MULLION IS A DOUGLAS FIR SAWN LUMBER SECTION.
  - 2.3. HORIZONTAL MULLION (ITEM NO. 7A AND 7B)
    - 2.3.1. BETWEEN TRANSOM PANEL(S) AND DOOR ASSEMBLY (OXXO, OXX, XXO, OX, XO, XX, X). SEE SECTIONS B/11 AND D/11.
    - 2.3.2. THE HORIZONTAL MULLION REQUIRES TWO 3" x 3" x 3/16" STEEL ANGLES (No. 44) INSTALLED AS SHOWN ON SHEETS 18 AND 19.
    - 2.3.3. ITEM NO. 7A MULLION IS A DOUGLAS FIR SAWN LUMBER SECTION.
    - 2.3.4. ITEM NO. 7B MULLION IS A FLITCH BEAM COMPRISED OF TWO SECTIONS OF DOUGLAS FIR SAWN LUMBER AND ONE 3/8" THICK BY 4-9/16" WIDE A-36 STEEL PLATE.
    - 2.3.5. WHEN HORIZONTAL MULLION LENGTH EXCEEDS 107" TOTAL ASSEMBLY DOOR WIDTH, ITEM 7B SHALL BE USED.
    - 2.3.5. WHEN HORIZONTAL MULLION LENGTH DOES NOT EXCEED OR IS EQUAL TO 107" TOTAL ASSEMBLY DOOR WIDTH, ITEM 7A SHALL BE USED.
- 2.4. SEE ILLUSTRATION ON SHEET 19 FOR INSTALLATION SCREWS LOCATIONS IN ITEM NO. 44 CLIP.
- 2.5. SEE ILLUSTRATIONS ON SHEET 18 FOR CLIP DETAILS, FLITCH BEAM DETAILS AND CLIP TO MULLION ATTACHMENTS.

SIMPSON DOOR COMPANY  
400 SIMPSON AVE.  
MCCLEARY, WA 98557

TITLE: HIGH IMPACT WOOD OUTSWING DOORS W/WO SIDELITES/TRANSOMS  
MULLION DETAILS

PREPARED BY: RJA  
SCALE: N.T.S.  
DATE: 6/18/21  
DRAWING NO: SIMP0027  
SHEET: 19 OF 20

Robert J. Amoruso, P.E.  
Florida P.E. No. 49752

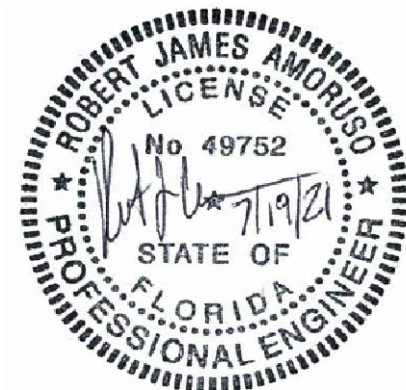

PROJECT NO. 421-0102

REV: DESCRIPTION DATE BY

\* ALL ELEVATIONS SHOWN ALSO QUALIFY 96", 84", AND 80" HEIGHTS AND ANY OTHER CUSTOM SIZES SMALLER THAN TESTED.

42" MAX. WIDTH  
108" MAX. HEIGHT

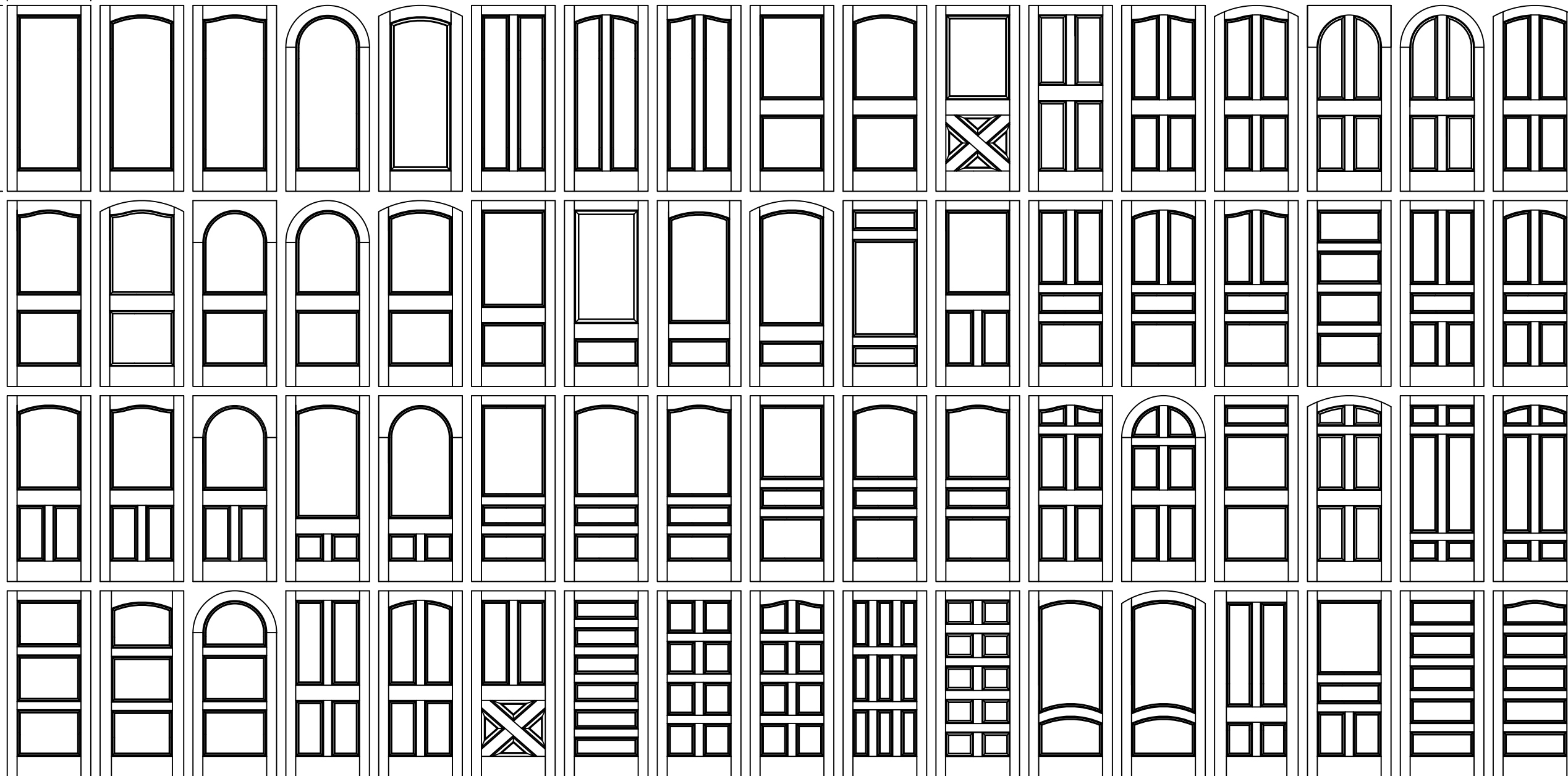

NOTE: DOOR PANELS MAY BE RECTANGULAR, ARCH, OR ROUND TOP.

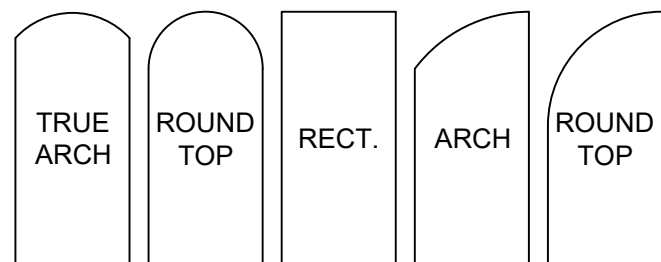

APPLICABLE PANELED PANEL DOORS

NOTE:  
V-GROOVES OPTIONAL FOR BOTH  
FLAT AND RAISED PANELS

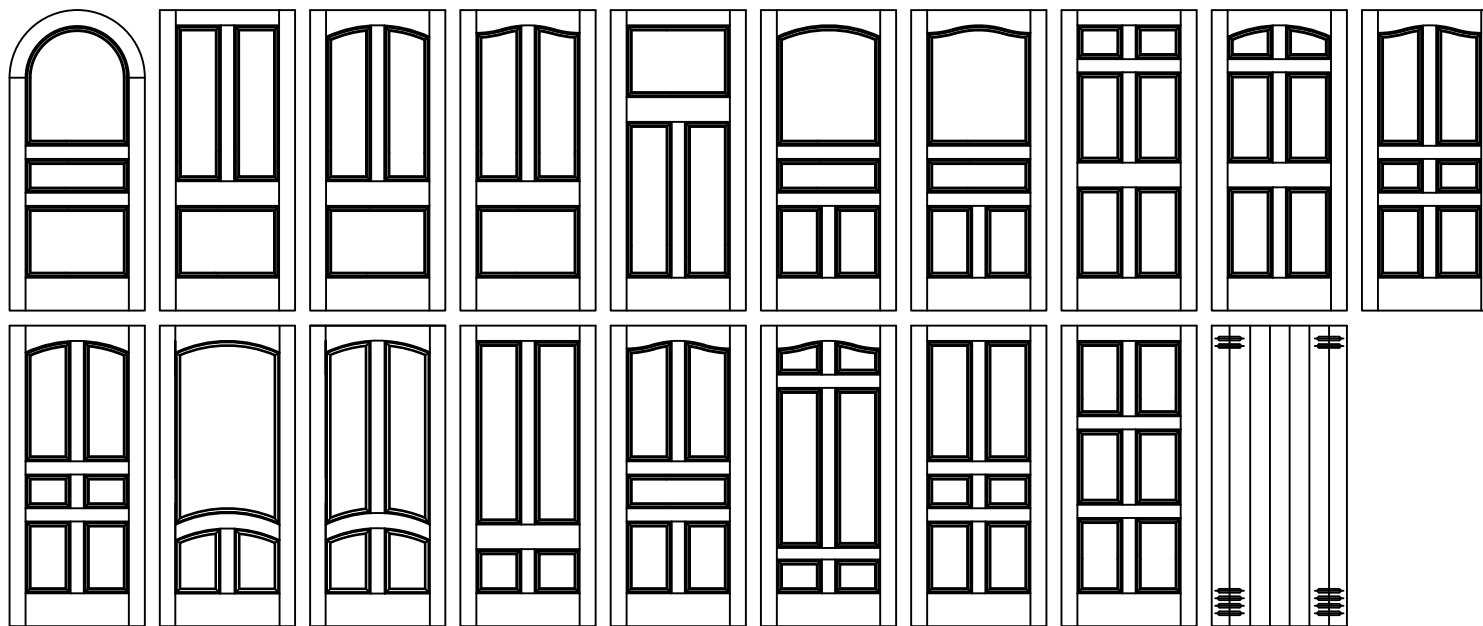

SIMPSON DOOR COMPANY  
400 SIMPSON AVE.  
MCCLEARY, WA 98557

TITLE: HIGH IMPACT WOOD OUTSWINGING DOORS W/VO SIDELITES/TRANSOMS  
APPROVED PANEL CONFIGURATIONS

PREPARED BY: RJA  
SCALE: N.T.S.  
DATE: 6/18/21  
DRAWING NO: SIMP0027  
SHEET: 20 OF 20



Robert J. Amoruso, P.E.  
Florida P.E. No. 49752

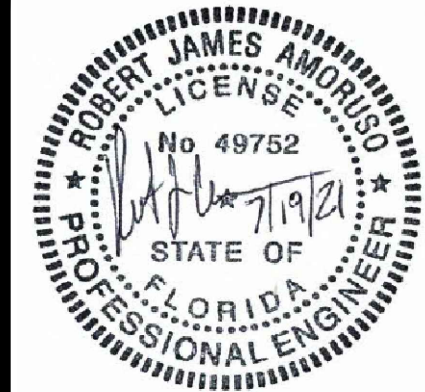

PROJECT NO. 421-0102

REV	DESCRIPTION	DATE	BY